

TRUE MOBILITY
WIRELESS SYSTEMS
OPERATING GUIDE
Version 4



Models:
SWM3000
SWM1600

WARNING : DON'T WORRY!

Every other wireless microphone manual has to warn users about the perils of feedback with wireless mics.

Welcome to Sabine True Mobility Wireless Systems, where the only feedback we get is how good it sounds!

ONLINE *Check out
what's new!*
product registration
SABINE
ADAPTIVE AUDIO
www.Sabine.com

DECLARATION OF CONFORMITY

Application of Council Directive: 73/23/EEC and 89/336/EEC

Standards to which conformity is declared:

EN 60065: 1993
EN 60950: 1992
EN 55103-1: 1997
EN 55022: 08:94 + a1:05:05
EN 55103-2: 1997
ETS 300445 (VHF)
ETS 300442 (UHF)

Manufacturer's Name: Sabine, Inc.

Manufacturer's Address: 13301 Highway 441
Alachua, FL 32615 USA

Type of Equipment: Wireless microphone/receiver

Model No.: True Mobility Wireless Systems

Serial No.:

Year of Manufacture: 1999 following

I, the undersigned, hereby declare that the equipment specified above conforms to the above Directive and Standard.

Place: Alachua, Florida, USA

Signature: 

Date: January 4, 2002

Full Name: Doran Oster, Sabine President

Table of Contents

SECTION ONE : INTRODUCTION	6
1.1 Using this Operating Guide	6
1.2 System Description	6
1.3 System Features	7
SECTION TWO : FRONT & BACK PANEL VIEWS	8
2.1 Back Panel View	8
2.2 UHF Front Panel View	8
2.3 VHF Front Panel View	8
SECTION THREE : SYSTEM COMPONENTS	9
3.1 Handheld Microphone	9
3.2 Beltpack Transmitter	9
3.3 Model Numbers and Accessory Part Numbers	9
SECTION FOUR : QUICK SETUP	10
4.1 Receiver & Transmitter Quick Setup	10
4.2 FBX Quick Setup	10
SECTION FIVE : RECEIVER & TRANSMITTER SETUP	11
5.1 Multiple Units	11
5.1.1 Number of Simultaneous Systems	11
5.1.2 Antenna Dividers & Extension Antennas	11
5.2 Receiver Placement and Connections	11
5.2.1 Power Cords & Antennas	11
5.2.2 Receiver Placement.....	11
5.2.3 Audio Output Connection.....	12
5.2.4 Beltpack Headset/Lavalier Microphone connection.....	13
5.3 Transmitter & Receiver Operating Procedures	13
5.3.1. Start-up Procedures	13
5.3.2. Transmitter LED Indicators	14
5.4 Group & Channel Selection	15
5.4.1 Selecting Transmitter/Receiver Groups/Channels	15
5.4.2 Group/Channel Selection (Multiple Receivers/Transmitters)	15
5.5 Audio Output Settings	16
5.5.1 Unbalanced Audio Output.....	16
5.5.2 Balanced Audio Output	16
5.6 Transmitter Battery Installation	16
5.6.1 Battery Usage	16
5.6.2 Handheld Microphone (SW30-H, SW16-H).....	17
5.6.2 Beltpack Transmitters (SW30-TX, SW16-TX)	17
5.7 Dual Battery Charger	18

SECTION SIX : FBX FEEDBACK EXTERMINATOR 19

6.1 Introduction to FBX 19

6.2 Two FBX Advantages 20

 6.2.1 Advantage #1 20

 6.2.2. Advantage #2 20

6.3 Who Needs The FBX? 21

6.4 FBX Setup & Ready Mode 21

 6.4.1 FBX Fixed & Dynamic filters 21

 6.4.2 Default FBX filter settings 22

 6.4.3 FBX filter width 22

6.5 How To Set Up The FBX Section Of Your True Mobility™ System 22

6.6 Bypass Button 23

SECTION SEVEN : DE-ESSER SET UP 24

7.1 The Essence of De-essing 24

7.2 Using the De-esser 24

SECTION EIGHT : COMPRESSOR SET UP 25

8.1 Basics of Compression 25

8.2 Using the Compressor 25

8.3 Suggested Compressor Settings 26

 8.3.1 Vocal Compression 26

 8.3.2 Guitar Compression 26

 8.3.2 Additional Settings 26

8.4 Possible Compression Trouble Areas 27

SECTION NINE : TIPS AND TROUBLESHOOTING 28

9.1 Tips for Maximum Performance of your True Mobility Wireless System 28

9.2 Troubleshooting 28

SECTION TEN : MULTIPLE FREQUENCY & USE CHARTS 29

10.1 UHF Frequency Code U922A [USA] 29

10.2 UHF Frequency Code U808C [Export] 30

10.3 UHF Frequency Code U794A [Export] 30

10.4 VHF Frequencies [USA] 31

10.5 VHF Frequencies [Export] 32

SECTION ELEVEN : APPENDICES 33

11.1 FBX Configuration DIP Switch 33

11.2 Beltpack Transmitter Connector Wiring Diagrams 34

11.3 XLR Connector 35

11.4 Beltpack Transmitter Schematic 35

11.5 Engineering Specifications 36

SECTION TWELVE : CAUTIONS & WARRANTY 38

INDEX 40

SECTION ONE : INTRODUCTION

Congratulations on purchasing a Sabine True Mobility™ Wireless System. True Mobility™ Wireless Systems give you all the built-in processing you need on every microphone.

1.1 Using this Operating Guide

This operating guide covers all Sabine True Mobility™ Wireless Systems — model numbers SWM3000 and SWM1600 — and contains full explanations for everything you need to operate your True Mobility™ Wireless system.

- Section 2** shows front and back panel views for your True Mobility Wireless receiver.
- Section 3** lists system components.
- Section 4** gives the Quick Setup procedures for Receiver & Transmitter Operation and using the FBX Feedback Exterminator®. Note that there is also a quick-start label on top of your True Mobility receiver for the Sabine FBX Feedback Exterminator®, Compressor/Limiter and De-Esser functions.
- Section 5** details receiver and transmitter installation and setup.
- Section 6** explains the how and why of Sabine's FBX technology, and gives a complete understanding of how to set up your FBX filters.
- Section 7** details the True Mobility's De-Esser.
- Section 8** explains the use of the Compressor.
- Section 9** gives tips on how to get the best performance from your Sabine Wireless, and describes some possible operating problems and their solutions.
- Section 10** has frequency charts for all currently available Sabine Wireless systems.
- Section 11** contains information on how to modify your True Mobility's FBX filters (**NOTE: these procedures are to be performed by qualified personnel only**), transmitter wiring schematics, and engineering specifications for your Sabine Wireless.
- Section 12** states caution and warranty information for your True Mobility™ Wireless system.

1.2 System Description

Sabine **True Mobility™ Wireless Systems** come in UHF and VHF models, with many accessories to complete your system packages. Both systems include state-of-the-art Phase Locked Loop (PLL) synthesized transmitter and receivers, **True Diversity** reception, dual-squelch circuitry, excellent noise rejection and superior dynamic range. Microphone transmitter configurations consist of handheld, lavalier, or headset styles. Sabine **True Mobility™ Wireless** UHF and VHF systems offer optional front or rear mount antennas, extension antennas, and antenna divider systems.

Sabine Wireless Systems are superior to conventional systems because we include the two most comprehensive features found in any wireless system: **True Mobility** and **Targeted Input Processing**.

We call our system True Mobility because it provides the freedom you should expect from a wireless system. With a conventional wireless system, your range of movement is limited by the potential for feedback in acoustical "hot spots." Some areas are so feedback prone you cannot go near them at all. Other areas allow only minimal gain before feedback occurs. Until now, freedom from mic cables meant more likelihood for feedback.

Fortunately, that has changed. Sabine's True Mobility system includes our patented, industry-standard **FBX Feedback Exterminator®**. Your microphones will sound loud and clear without feedback, and with a greatly increased area of feedback-free movement. This is the freedom you were seeking when you chose a wireless system.

Sabine's True Mobility doesn't stop with automatic feedback control. Conventional wireless systems require the added cost of outboard equalizers, compressor/limiters, and de-essers to maximize performance.

Sabine offers a different approach: **on-board processing at no extra cost**, all dedicated to one microphone. We call this Targeted Input Processing. With Targeted Input Processing, no mic gets more processing than it needs, and every mic gets precise, targeted control perfectly suited to provide optimal performance.

1.3 System Features

All Digital Targeted Input Processing

- **Patented FBX Feedback Exterminator®:** The industry standard in automatic feedback control. The True Mobility FBX function includes our fast Turbo Setup Mode, 10 FBX filters, and easy-to-use controls.
- **Auto De-Esser:** Sabine's new automatic de-essing algorithm senses, tracks, and removes sibilance without affecting the rest of your program.
- **Compressor:** Our famous digital compressor offers the gain management you need to compensate for all types of performers and speakers, from those who are shy around microphones, to the boldest worship leader. You can adjust ratio, threshold and attack settings.

True Diversity Receiver

- **Phase Locked Loop (PLL):** Receiver and transmitter are synthesizer controlled via PLL circuitry.
- **Dual-squelch Circuitry:** Sabine 2-stage squelch utilizes Tone Key and Noise squelch systems which eliminate interference and provide quiet, reliable and flexible service.
- **Dual-NiMH 9-volt Battery Charger:** on-board dual-NiMH 9-volt battery charger means you are never out of power for handheld transmitters—saves you hundreds of dollars a year in 9-volt battery costs! Transmitter low-battery warning light lets you know when to change. Sabine's NiMH batteries give you up to 5 hours of battery life and only MINIMAL MEMORY EFFECT! *
- **Radio Frequency (RF) and Audio signal meters:** Bright, easy-to-see-and-read level meters keep you informed of signal strength and audio level.
- **User-friendly Channel (and Group for UHF) Selection on Transmitters:** The RF signal meter helps you find a clear frequency.
- **Options include:** Rear-to-Front Antenna Converter Kit, Antenna Divider Systems, Extension Antennas and Extension Antenna Boosters (Extension Antenna Booster raises the signal +13 dB and requires use of Antenna Divider).

* **NOTE:** MEMORY EFFECT typically occurs when a NiCAD rechargeable battery is recharged before reaching the end of its **initial** charge. The battery remembers the charge state prior to being recharged and uses that as its "empty" charge state. Sabine NiMH batteries are "memory resistant." You can recharge your batteries any time you please; whether they are 1/2, 3/4 or almost fully charged. You will always get consistent battery life from your Sabine NiMH batteries (for up to 500 charges or more).

SECTION TWO : FRONT & BACK PANEL VIEWS

2.1 Back Panel View

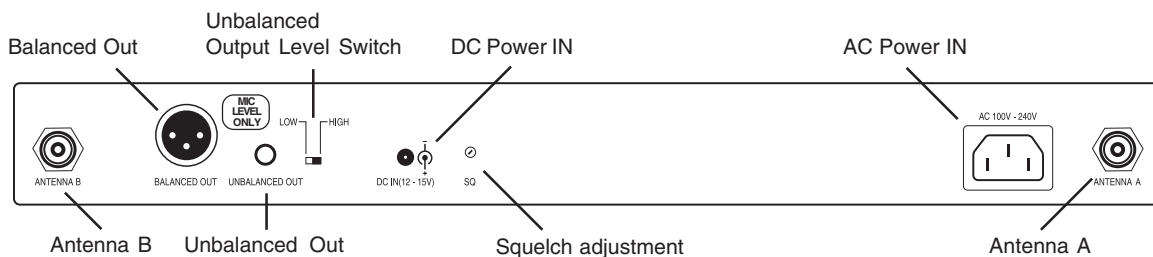

2.2 UHF Front Panel View

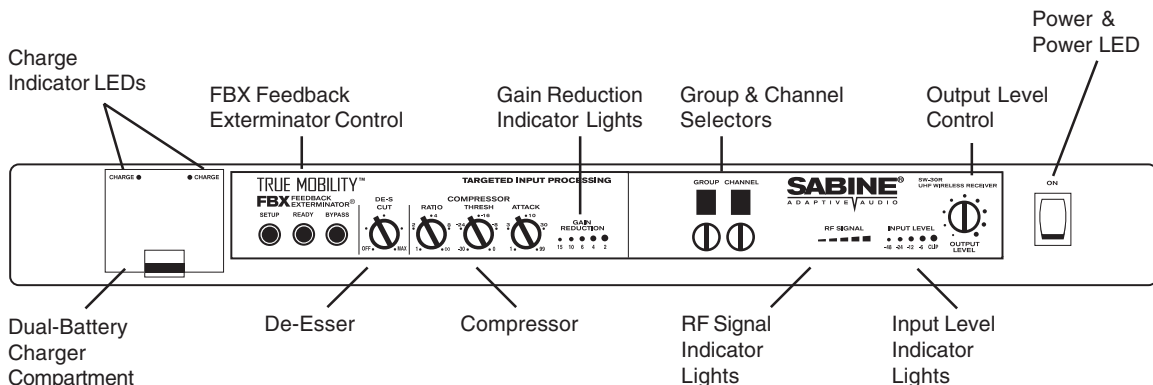

WARNING:

Do not attempt to recharge alkaline or other non-rechargeable batteries. Non-rechargeable batteries will explode if placed in a battery charger. For best results, use Sabine 7.2-volt rechargeable batteries (SWABAT).

2.3 VHF Front Panel View

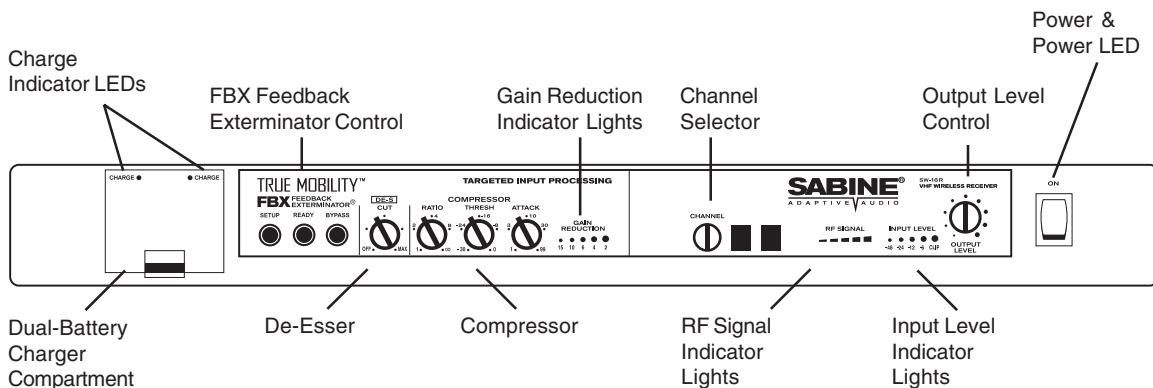

SECTION THREE : SYSTEM COMPONENTS

3.1 Handheld Microphone

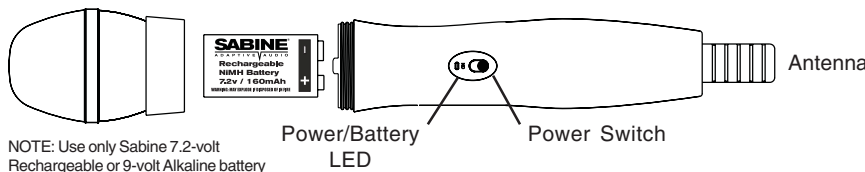

NOTE: Use only Sabine 7.2-volt Rechargeable or 9-volt Alkaline battery

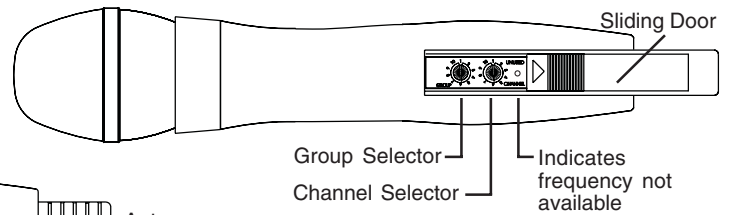

NOTE: SWM1600 VHF microphones and transmitters do not have a GROUP selector.

3.2 Backpack Transmitter

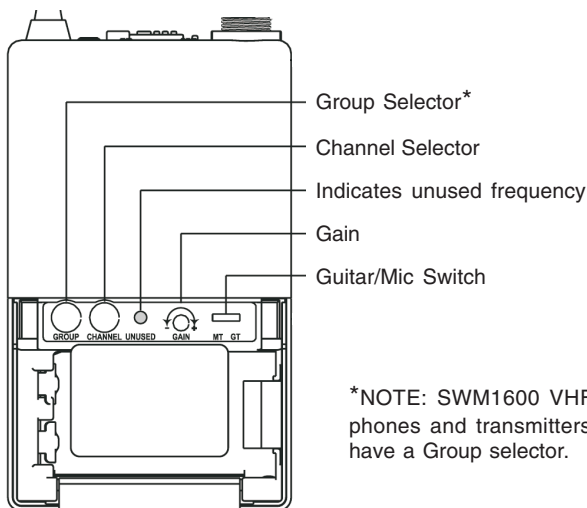

*NOTE: SWM1600 VHF microphones and transmitters do not have a Group selector.

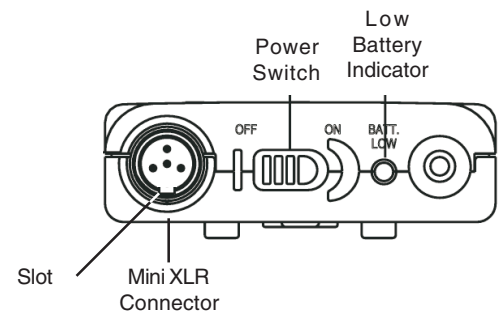

3.3 Model Numbers and Accessory Part Numbers

SWM3000 UHF System

- SWM3000-H** UHF Handheld Package (SW30-R, SW30-H)
- SWM3000-LX** UHF Lavalier Package (SW30-R, SW30-TX, SWT42L-4PX)
- SWM3000-DX** UHF Headset Package (SW30-R, SW30-TX, SWT25W-4PX)
- SW30-R** 30-Ch Diversity Receiver with Battery Charger & NiMH rechargeable battery
- SW30-H** Condenser PLL Hand Held Microphone
- SW30-TX** PLL Belt Pack Transmitter, 4-pin Mini XLR

SWM1600 VHF System

- SWM1600-H** VHF Handheld Package (SW16-R, SW16-H)
- SWM1600-LX** VHF Lavalier Package (SW16-R, SW16-TX, SWT42L-4PX)
- SWM1600-DX** VHF Headset Package (SW16-R, SW16-TX, SWT25W-4PX)
- SW16-R** 16-Ch Diversity Receiver with Battery Charger & NiMH rechargeable battery
- SW16-H** Condenser PLL Hand Held Microphone
- SW16-TX** PLL Belt Pack Transmitter, 4-pin Mini XLR

Microphones

- SWT42L-4PX** Unidirectional Lavalier Microphone, 4-pin Mini XLR
- SWT25W-4PX** Unidirectional Headset Microphone, 4-pin Mini XLR
- SWT30G-4PX** Guitar Plug and Cable, 4-pin Mini XLR

Batteries

- SWBBAT** Rechargeable 7.2-volt NiMH Battery for transmitters

Antenna Accessories

- SWA100** TNC Rear to Front Antenna Converter Kit
- SWA4V** VHF 4-Channel Antenna Divider System
- SWAVEXT** VHF Extension Antenna (1 set of 2)
- SWA4U** UHF 4-Channel Antenna Divider System
- SWAUEXT** UHF Extension Antenna (1 set of 2)
- SWAUB** UHF Extension Antenna Booster *
- SWAEXTM** Mounting Bracket for Extension Antenna (1 set of 2)

Mic & Transmitter Accessories

- SWC200** Condenser Microphone Capsule Module
- SWCCLIP-H** Handheld Microphone Holder
- SWCTRI** Desktop microphone tripod
- SWC4P** 4-pin connector
- SWCCLIP-L** Mic clip for SWT42L-4PX Lav Mic
- SWCSCR2** Windscreen for Lav Microphones

* Extension Antenna Booster requires use of Antenna Divider.

SECTION FOUR : QUICK SETUP

4.1 Receiver & Transmitter Quick Setup

Please read **Section Five Receiver & Transmitter Setup** for a complete understanding of how to set up your True Mobility Receiver.

1. Place the receiver in an open area within visual range of the intended microphone locations. Note that the range of your microphones is about 100 meters, but that structural objects can lessen that range.
2. Turn the Output Level of the receiver and mixer in use to the minimum setting.
3. Connect the unbalanced output (1/4 inch jack) of your True Mobility receiver to the unbalanced input of your mixer or amplifier; or the balanced output (XLR connector) of your receiver to the balanced mic input of your mixer or amplifier.

NOTE: when putting the unbalanced output of the receiver into the Line In input jack of a mixer or amplifier, switch the receiver's Level Switch to the High position (see p.10, Fig. 5d). If you connect the unbalanced output of a receiver into the Mic-In input jack of a mixer or amplifier; switch the receiver's Level Switch to the Low position.

4. Turn on Receiver. **Set receiver and transmitter to same Group and Channel.** Make sure your transmitter is turned off.
5. **Check that the RF Signal LEDs are not lighting up.** If RF Signal LEDs light up before transmitter is turned on, choose another frequency.
6. Turn on wireless microphone or transmitter. Check that the REF Signal LEDs are lit.
7. Adjust volume.
 - a. Speak into the microphone. Adjust the transmitter Gain until Input Level LEDs (on receiver) light without clipping. **NOTE: Step 7.a** is for beltpack transmitters only—the Transmitter Gain is not adjustable on handheld microphones.
 - b. Adjust the receiver Output Level to approximately the 12 o'clock position (or loud enough to supply a strong input level to the mixer or amplifier).
 - c. Adjust the volume control of the amplifier and/or mixer to an appropriate sound level.

4.2 FBX Quick Setup

Please read **Section 6.6 How to Set Up the FBX Section of your True Mobility System** for a complete understanding of the FBX function and control.

1. Patch the Sabine receiver into your mixer or amp and position the speakers; then turn on the receiver, transmitter, and microphone. Look for strong RF signal on the front panel meter; check microphone and adjust **Output Level** for strong input level on the mixer or receiver's amp.
2. Position the microphone in the primary area of use; press and hold the **Setup** button on the receiver until the **Setup** indicator flashes 4 times, then release. **Do not use microphone for performance in this mode. Do not talk into microphone until setup is complete.**
3. **Slowly** raise the gain on the mixer or amp channel until FBX eliminates the first few feedback tones. Stop raising gain.
4. Move the microphone to another area of use and **slowly** raise gain until FBX eliminates a few more feedback tones.
5. Repeat step 4 until the **Setup** indicator automatically goes off and the **Ready** indicator comes on.

You may quit Setup mode at any time prior to its automatic exit by simply pressing the Ready button.

NOTE : The **Bypass** button bypasses **only** the FBX filters, and not the additional signal processing (de-essing and compression) available in the Targeted Input Processing section of the Sabine True Mobility™ Wireless Receiver.

SECTION FIVE : RECEIVER & TRANSMITTER SETUP

Each Sabine Wireless System consists of a transmitter and a receiver. Sabine's True Mobility Wireless receivers are True Diversity receivers—that means they have two fully redundant receivers listening for your transmitter and trading off automatically to whichever receives the best signal.

5.1 Multiple Units

5.1.1 Number of Simultaneous Systems

UHF receivers/transmitters have 30 frequencies to choose from, but there is a **maximum number that can be used in one location** (see **Section Ten: Multiple Frequency & Use Charts** for more information and setup). VHF receivers/transmitters have 16 frequencies to choose from. These also have a **maximum number that can be used on one location**. UHF and VHF systems can be used together to increase the number of units. Refer to your receiver Frequency Code and the corresponding information in **Section Ten: Multiple Frequency & Use Charts** for how to set up multiple receivers and transmitters.

5.1.2 Antenna Dividers & Extension Antennas

When multiple UHF or VHF systems are in use, a Sabine antenna divider (UHF systems: SWA- 4U; VHF systems: SWA- 4V) can be used to minimize the number of antennas. Extension antennas can be added to maintain good reception even when receivers are far from transmitters.

5.2 Receiver Placement and Connections

5.2.1 Power Cords & Antennas

Attach the power cord to the AC Power IN on the back panel and to a 120 - 240-volt AC power source (alternatively, you may use a 12-15 VDC, 0.6A, 10W power adapter as in Figure 5b). Attach antennas or antenna connectors to the antenna A & B TNCs on the True Mobility back panel.

5.2.2. Receiver Placement

The receiver should be placed in an open area within visual range of the intended microphone location. Note that the range of your transmitter is about 100 meters, but that structural objects can lessen that range. Extension antennas can be added to maintain good reception even when the receiver is located far from the transmitter.

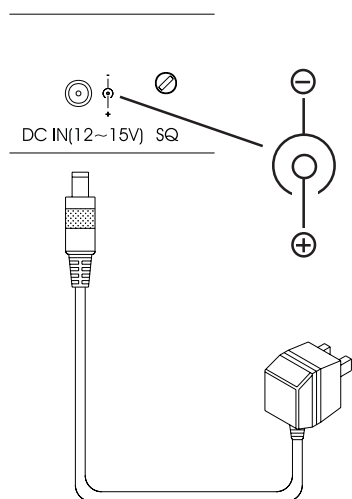

Figure 5b - DC Power Connections

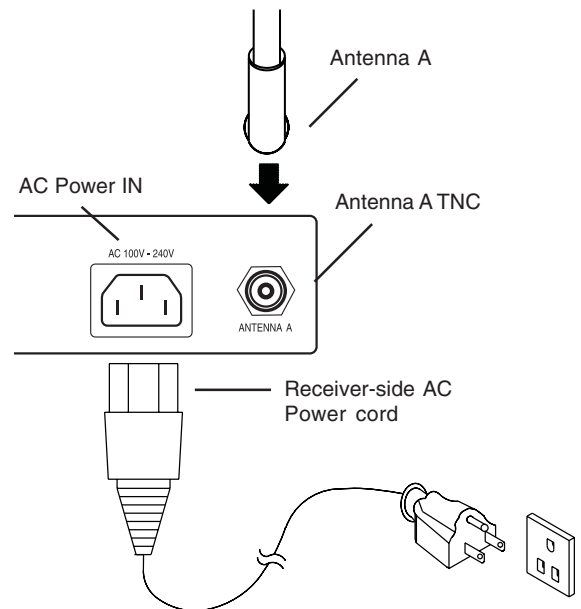

Figure 5a - AC Power and Antenna Connections

CAUTION: Do not use third party receivers or transmitters as part of, or in conjunction with your Sabine Wireless system. Some third party microphone and pickups can be configured to work with the Sabine True Mobility. See Appendix 11.2 for wiring diagrams.

CAUTIONS

- Since the installation of the antennas influences the operating efficiency of the receiver, the most important rule is to minimize the distance between receiving antenna and transmitter for better reception and performance.
- Keep the system away from electrical-noise sources (electric motors, refrigerators, arc welders, etc.). Place the receiver at least one meter above floor level. Keep all transmitters at least 3 meters away from a receiver antenna.

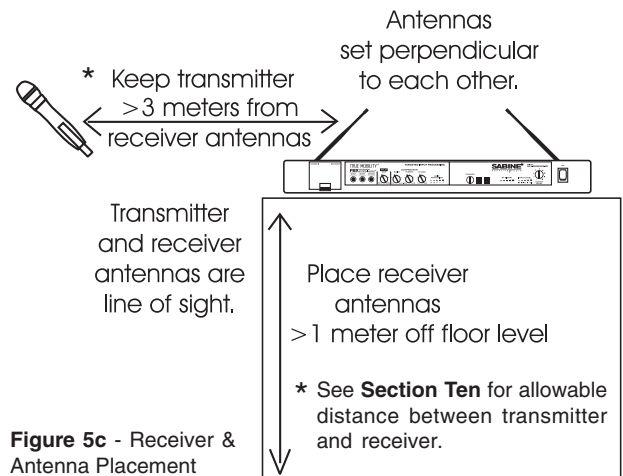

Figure 5c - Receiver & Antenna Placement

Your True Mobility receiver can be installed into an EIA standard rack-mount case using the rack-mount brackets provided. A Rear-to-Front Antenna Converter Kit (SWA100) is available to improve reception on rack-mounted receivers.

5.2.3 Audio Output Connection

Connect the unbalanced output (1/4 inch jack) of your True Mobility receiver to the unbalanced mic input of your mixer or amplifier; or the balanced output (XLR connector) of your receiver to the balanced mic input of your mixer or amplifier.

NOTE 1 : The Level Switch affects only the Unbalanced Output on the receiver. In the “Low” position, the output is the same as the Balanced (XLR) output. In the “High” position, the output is 10 dB higher than the XLR output.

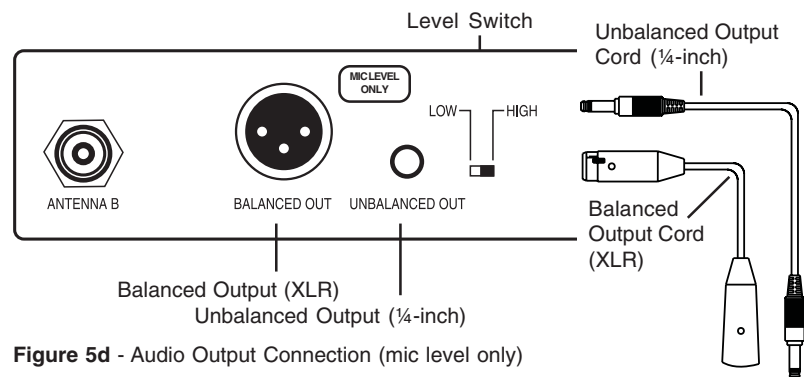
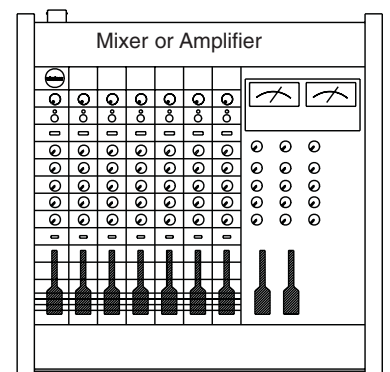

Figure 5d - Audio Output Connection (mic level only)

NOTE 2 : Guitar Output: Using 1/4-inch jack cable, plug one end into the receiver’s unbalanced output and the other end to the input of a guitar amplifier. Switch the Level Switch to the High position.



5.2.4 Beltpack Headset/Lavalier Microphone connection

Plug the Headset or Lavalier connector into the 4-pin threaded connector located on top of the UHF of VHF beltpack transmitter. Be careful to align the notch on the inside of the cord connector with the slot on the inside of the beltpack connector.

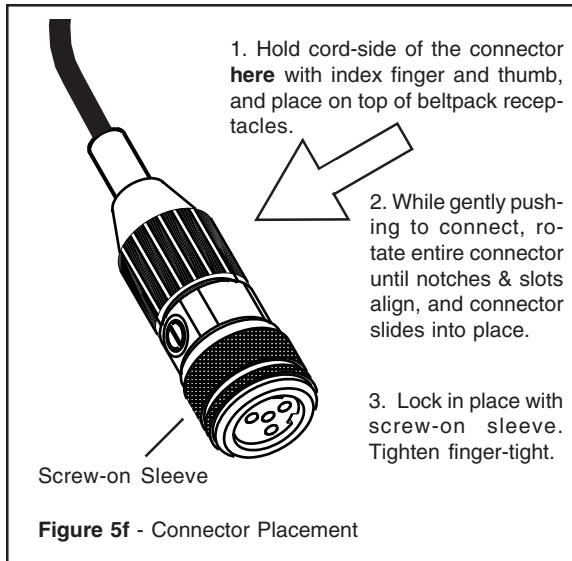
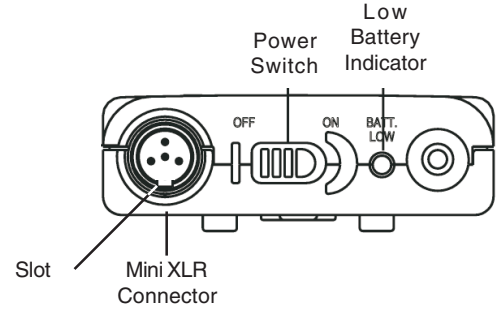

Figure 5f - Connector Placement



NOTE: See Section 11.2 Beltpack Transmitter Connector Wiring Diagrams for Sabine True Mobility connector wiring information.

5.3 Transmitter & Receiver Operating Procedures

5.3.1. Start-up Procedures

1. Power up the True Mobility receiver. The red LED on the power switch will indicate power is on.

2. Check RF Signal indicator LEDs. Other signal sources, including other wireless communication devices and transmitters, can interfere with the operation of your receiver. Before turning on your microphone or beltpack transmitter, check to see if any of the RF Signal LEDs on the receiver are lit. The number of LEDs that light up will indicate the strength of the interference.

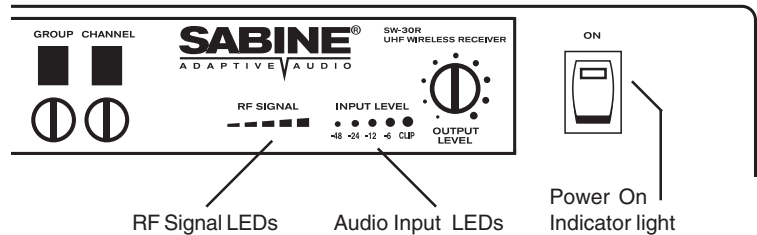

Figure 5g - Receiver Controls & LEDs

NOTE: Some interference can be dealt with using Sabine's two-stage squelch. Adjust the Squelch control knob ("SQ" on rear panel of unit) clockwise until all RF Signal LEDs go out.

CAUTION: Increasing the squelch threshold will shorten the operating distance possible between microphone and receiver. A much better solution is to use the Group and Channel selectors to locate a frequency without interference or with minimal interference.

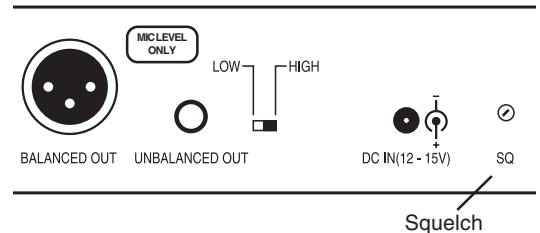

Figure 5h - Receiver Back Panel Squelch Control

3. Power up your mixer and or amplifier. Turn volume controls to the minimum setting.

- Turn on your Sabine Wireless microphone or beltpack transmitter. Select the same Group/Channel as the receiver (see **Section 5.4 Group & Channel Selection**). Under normal circumstances, the RF Signal indicator on the receiver will light up when a transmitter is turned on within operating range of that receiver.

NOTE: The Sabine Wireless receiver has a two-stage squelch system that allows you to turn on or off your transmitter while the receiver and sound system are on—without causing pops or clicks from the Sabine Wireless system.

- Speak into the microphone. When audio program is added to that RF signal, the Input Level indicators will light up in accordance with the strength of the audio signal. Adjust transmitter Gain to maximum signal **without clipping** (NOTE: Handheld microphones do not have gain control).
- Adjust mixer and amplifier levels.

5.3.2. Transmitter LED Indicators

Sabine True Mobility transmitters incorporate multifunction LED indicators. These LEDs signify a variety of information depending on when and for how long they are lit.

The handheld microphone has an LED next to the Power Switch (Figure 5i), and one inside the Group/Channel Selector compartment (Figure 5k). The Beltpack Transmitter has both LEDs together on the front control panel.



Figure 5i - Handheld Microphone Power/Battery LED

5.3.2.1 Power/Battery LED. The Power/Battery LED comes on when you first insert the battery (Handheld Microphone only), and when you first turn the microphone/transmitter on. It stays on for about two seconds and signifies that the microphone/transmitter is in mute mode during that time. The LED will then go off automatically, signifying that the microphone/transmitter is now in active mode. If, after turning on the microphone/transmitter, the LED comes on and stays on, this signifies that the battery is weak and should be replaced with a Sabine rechargeable battery from inside the built-in battery compartment.

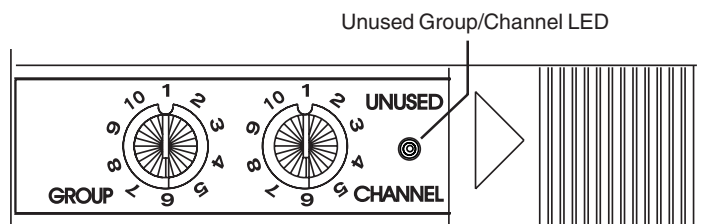

Figure 5k - Handheld Microphone Channel LED

5.3.2.2 Unused Group/Channel LED.

This LED comes on for about two seconds whenever you change a Group/Channel setting. If the LED stays on, then the setting you have selected is not available, and you need to select another. Please refer to the Group/Channel chart for your system in **Section Ten**.

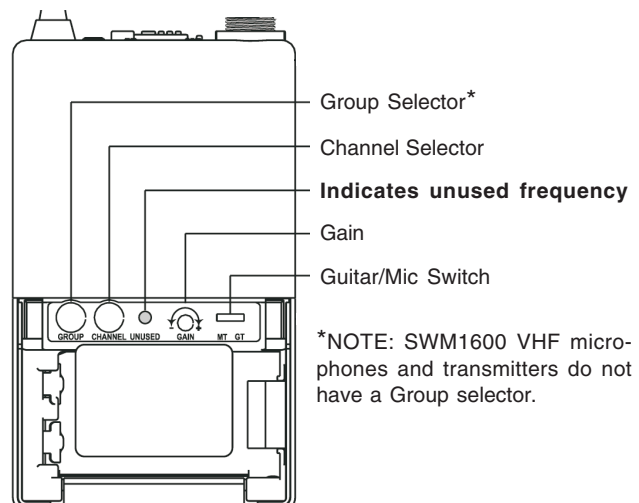

Figure 5j - Beltpack Transmitter LEDs

5.4 Group & Channel Selection

Sabine True Mobility UHF Wireless transmitters are preprogrammed with 30 switchable combinations of Groups/Channels; True Mobility VHF Wireless transmitters are preprogrammed with 16 switchable Channels. Both systems allow easy change of transmitter settings.

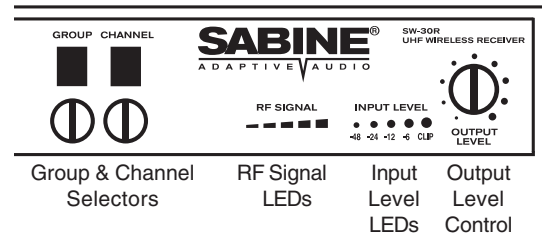

Figure 5l - Receiver Group/Channel

Change Group/Channel when:

- RF Signal indicator lights flash when you do not have a microphone or transmitter turned on.
- You have several True Mobility Wireless systems operating at once. **Each system must operate at a unique Group and/or Channel setting** (see Section Ten).

5.4.1 Selecting Transmitter/Receiver Groups/Channels

1. Turn on the True Mobility receiver — leave transmitter in off position.
2. Check for RF interference. If the RF Signal LEDs are lighting up, set Group and/or Channel selectors to a different setting. Repeat this until a clear channel is located (no RF signal).
3. Using your fingernail or small screwdriver, **carefully** set the Group and/or Channel knobs on the transmitter to the same setting as the receiver (handheld microphone Group and Channel selectors are located inside the sliding-door compartment above the antenna).

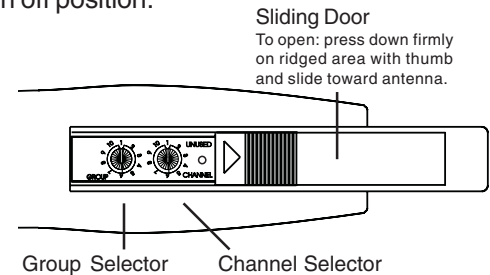

Figure 5m - Handheld Group/Channel Selectors

NOTE: SWM1600 VHF systems do not have a Group selector

4. Turn on the transmitter and check to see if the **RF Signal LEDs** light up.

5.4.2 Group/Channel Selection (Multiple Receivers/Transmitters)

SWM3000 UHF transmitters and receivers have both Group and Channel selector knobs. The channels within each group have been arranged so that you can use multiple wireless units at a single location, without having the units interfere with each other. Refer to **Section Ten Multiple Use & Frequency Charts** for how to use multiple True Mobility Wireless Systems together.

NOTE : If you are using only one Sabine True Mobility Wireless transmitter/receiver, simply select a group/channel that does not indicate interference. See Section 5.3, #2 to determine if there is RF interference present at your location.

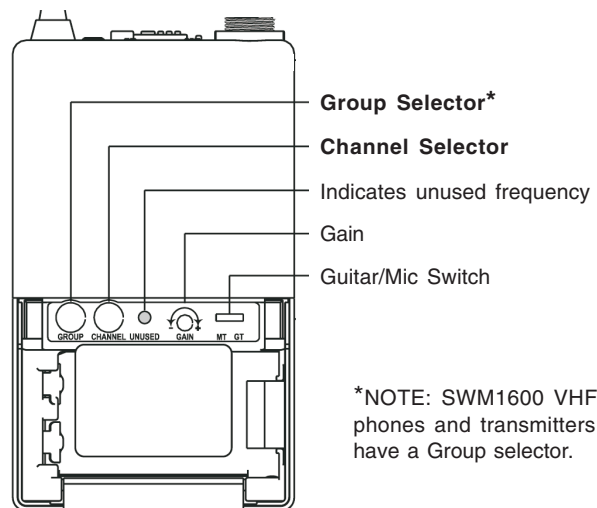

*NOTE: SWM1600 VHF microphones and transmitters do not have a Group selector.

Figure 5n - Beltpack Group/Channel Selectors

5.5 Audio Output Settings

5.5.1 Unbalanced Audio Output

Follow these steps to adjust Unbalanced Audio Output from your True Mobility receiver (refer to **Section 5.2.3. Audio Output Connection** for information on balanced/unbalanced audio connection).

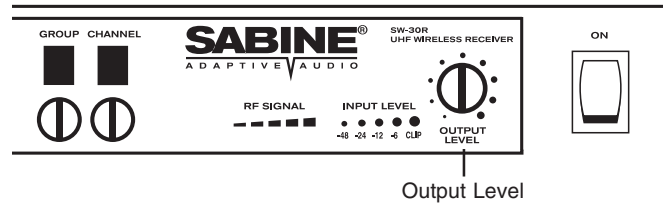

Figure 5o - Audio Output

1. Switch the **Level Switch** on the receiver rear panel to the “**Low**” position. If you are plugging into a microphone input on a mixer or amplifier. See **Note 1** on page 12 for **Level Switch** information.
2. Adjust the receiver **Output Level** knob to the 12 o’clock position (straight up).
3. Adjust the volume control of the amplifier or mixer to an appropriate sound level.

NOTE : The **Output Level** control on the receiver is used for fine tuning the wireless microphone output. At the 12 o’clock position, the output level of the wireless microphone is the same as that of most standard dynamic microphones.

5.5.2 Balanced Audio Output

1. Adjust the receiver **Output Level** knob to the 12 o’clock position (straight up).
2. Adjust the volume control of the amplifier or mixer to an appropriate sound level.

NOTE: Balanced Output is not affected by the Level Switch setting

CAUTION: If the receiver Output Level is set too high, it will cause your sound to be distorted. Conversely, signal to noise ratio (S/N) will worsen if the receiver Output Level is adjusted too low.

For more information on getting the most out of your True Mobility system, refer to **Section Nine Tips & Troubleshooting**

5.6 Transmitter Battery Installation

5.6.1 Battery Usage

Sabine True Mobility Wireless handheld microphones and UHF/VHF beltback transmitters are designed to use common 9-volt transistor batteries. An alkaline 9-volt battery (IEC 6LR61, or equivalent ANSI and NEDA 1604A) will typically provide 8 hours or more of operation.

Your True Mobility Wireless System comes with a Sabine rechargeable 9-volt size) Nickel Metal Hydride (NiMH) battery. This battery can be recharged using the built-in battery charger on your receiver. With a full charge, the typical life of a rechargeable battery is approximately 3 hours or more.

NOTE: Make sure to turn off the microphone/transmitter after use to extend the battery life. Remove the battery from the battery compartment if the microphone or transmitter will not be used for an extended period of time. Rechargeable batteries can be stored in the built-in battery charger on the receiver, however, the overall battery life (number of times the battery can be recharged) will be reduced somewhat.



CAUTION
DO NOT BURN OR PUNCTURE BATTERY. DOING SO COULD RELEASE TOXIC MATERIALS WHICH COULD CAUSE INJURY. DO NOT SHORT CIRCUIT



NOTICE
BATTERIES MUST BE RECYCLED OR DISPOSED OF PROPERLY

5.6.2 Handheld Microphone (SW30-H, SW16-H)

1. Grip the microphone capsule as shown in Figure 5p. Unscrew the top of the microphone (counterclockwise direction).

2. Insert a 9-volt battery into the battery compartment according to the correct polarity as shown in Figure 5p. Note that inside the microphone body, and at the bottom of the battery cavity, the hole for the positive contact is larger than the hole for the negative contact. The moment the battery touches the terminals inside the battery compartment, the

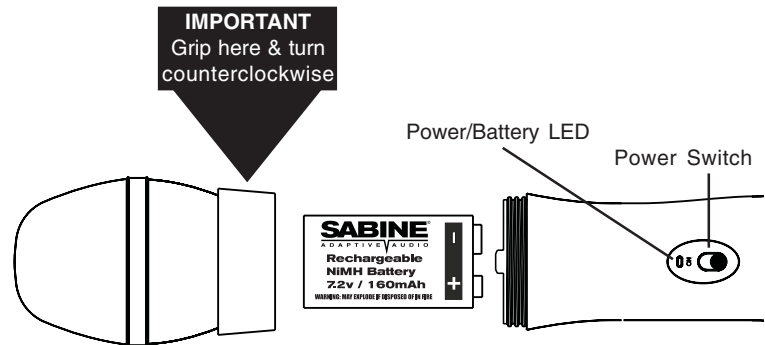

Figure 5p - Handheld Microphone Battery Replacement

- On/Battery Indicator will flash briefly. This means the polarity is correct. However, if no flash occurs, this indicates incorrect insertion, or the battery is dead. Please read **Section 5.3.2. Transmitter LED Indicators** for a complete understanding of Sabine multifunction LEDs.

3. Replace cap so that the three contact prongs inside the capsule align with the three silver contact squares inside the mic body. Tighten capsule finger tight.

CAUTION : Do not force. If the alignment is not correct or the battery is not placed correctly, the capsule will not close.

5.6.2 Beltpack Transmitters (SW30-TX, SW16-TX)

1. Press in on ribbed areas with thumb and index finger and pull up to open hinged battery door.
2. Note the positive and negative markings on the inside of the battery compartment. Place a 9-volt battery connector-side first into the battery compartment, making sure the polarity is correct.
3. Push in at ribbed areas and close door.

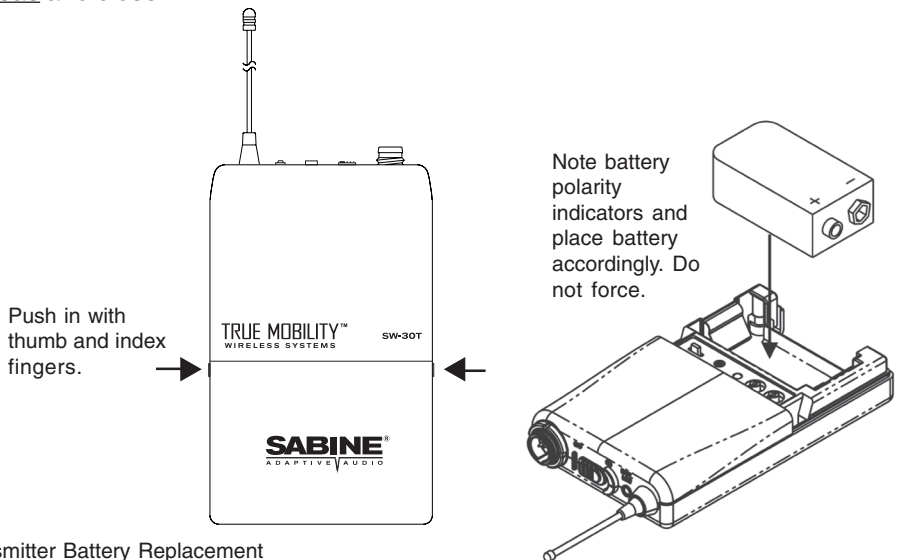

Figure 5q - Beltpack Transmitter Battery Replacement

NOTE when changing batteries during performance: The Sabine Wireless receiver has a two-stage squelch system that allows you to turn on or off your transmitter while the receiver and sound system are on—without causing pops or clicks from the Sabine Wireless system.

5.7 Dual Battery Charger

The battery charging system incorporates a proprietary built-in intelligent battery charger system on the receiver. It accommodates either one or two 7.2 volt rechargeable batteries. A red indicator light means that the charger is in a rapid-charge state. A green light means that the batteries have achieved at least the **minimum charge necessary for use**, and the charger is in a trickle-charge state. The green indicator light does not mean that the batteries are fully charged. **For full charge, we recommend that batteries be charged overnight.**

NOTE 1: Sabine NiMH batteries are shipped in a minimum charge state. We recommend that you charge your Sabine NiMH battery overnight before using it in a performance.

NOTE 2: As long as your True Mobility receiver is plugged in, batteries inside the charger will be charged. The receiver power switch does not affect the battery charger.

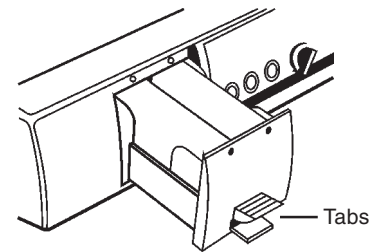

Squeeze tabs together and pull out to open.

Figure 5r - Built-in Battery Charger



CAUTION: DO NOT INSERT NON-RECHARGEABLE BATTERIES, DAMAGED BATTERIES OR FOREIGN OBJECTS INTO THE BATTERY CHARGER.

Sabine recommends using high-quality Sabine Rechargeable NiMH Batteries (SWBBAT). These batteries are available from your Sabine dealer.



Sabine NiMH Rechargeable Battery
SWBBAT

Standard 9-volt batteries also can be used in Sabine Wireless Systems—but do not insert them into the battery charger!

SECTION SIX : FBX FEEDBACK EXTERMINATOR

6.1 Introduction to FBX

WHY FBX? Feedback is certainly the most embarrassing, most pervasive challenge to the audio industry. The potential appearance of sudden, loud, out-of-control feedback is every sound engineer's and musician's nightmare. It disturbs the performer, the audience, and the technician; and can damage equipment and just generally ruin your day.

A typical wireless microphone adds a new level of unpredictability to feedback potential. Feedback involves a relationship between a speaker and a microphone, and the physical distance between the two is the principal determinant of feedback. A mic that can move anywhere results in an ever changing potential for feedback. A step in the wrong direction may change a clear, loud sound to a piercing shriek in less than a second. The potential for feedback with a wireless system is increased further if lavalier microphones are used. Lavalier microphones are placed farther from the mouth than handheld or head set microphones, and often require more gain. Lavalier microphones are also frequently omnidirectional, meaning they pick up sound equally from all directions, increasing the chance of feedback due to increased sensitivity to the sound emanating from the speakers.

The Sabine True Mobility™ solves this problem by attenuating very narrow bands of feedback-prone frequencies. The process is **automatic**, **simple** to use, **adaptable** to changing acoustical conditions and relationships, powerful in its application, and has minimal consequences to the audio fidelity of the signal. We call this automatic filter an **FBX Feedback Exterminator®** filter, or FBX filter for short.

Before the invention of FBX, the most common device for controlling feedback was the 31-band graphic EQ. However, FBX has three distinct advantages. The most obvious is that FBX functions automatically, even during the program. Another is that FBX micro-filters are precisely placed anywhere feedback occurs, while EQ filters are limited to 31 fixed centerpoints. The difference: FBX filters do not have to be as deep, so there is more system gain. But the most important advantage is that FBX micro-filters are ten times narrower than 31-band EQ filters. Using FBX micro-filters will return up to 90 percent of the power removed by EQ filters.

An EQ would need more than 10,000 sliders to be equivalent to your FBX. With FBX technology, your microphone will finally sound loud enough, everyone in the audience will understand each word, and feedback will be far less likely to make an unwelcome and unexpected visit.

Graphic EQ setting

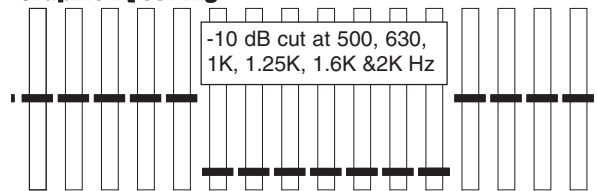

What people think happens...

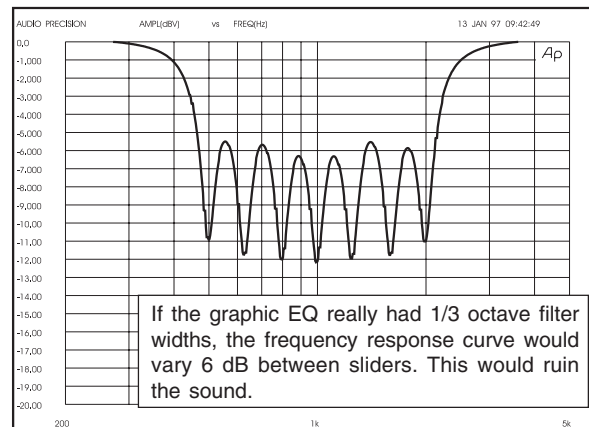

And what really happens to your program

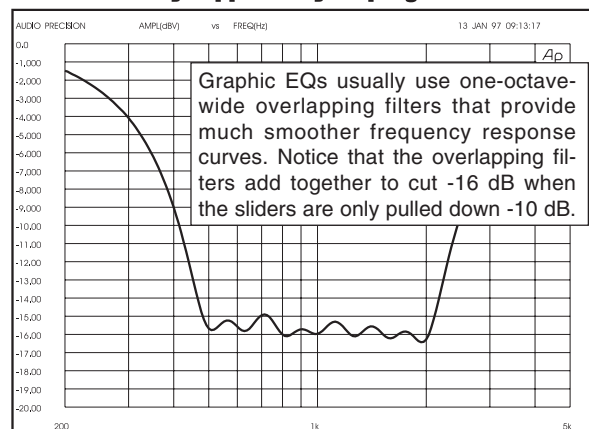

Figure 6a - Graphic-EQ effect on program

6.2 Two FBX Advantages

There are two reasons why the True Mobility™ system from Sabine is able to eliminate feedback while maintaining a high quality audio signal.

6.2.1 Advantage #1

First, an FBX filter represents a **direct hit on feedback!** The FBX targets feedback without taking a big chunk out of your sound. Tests prove that a single 1/3-octave EQ slider pulled down 12 dB removes almost half the power going to the speakers over a two-octave range. Furthermore, you can't place a graphic EQ filter precisely on the ringing frequency. If you pull down multiple sliders in a normal setup, you end up with giant frequency holes in your music (see Figure 6b). On the other hand, FBX micro-filters are 10 times narrower—you get back up to 90% of the power you lose with a graphic EQ! That means more gain before feedback and no loss in sound quality.

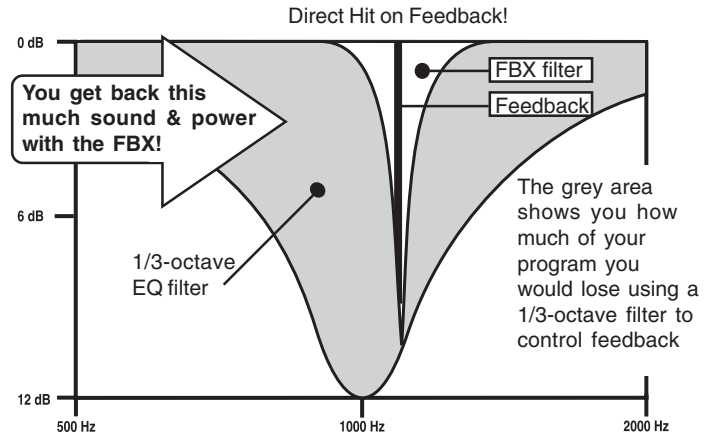

Figure 6b - FBX Filters a Direct Hit on Feedback

EXAMPLE: In Figure 6c, a PA system was set up using a microphone, mixer, FBX Feedback Exterminator®, power amp and two speakers. The system's gain was raised until the FBX removed nine feedback points. Next, the FBX was replaced with a graphic EQ. The EQ was adjusted while the system gain was raised to the same level achieved with the FBX. The frequency response curves of each device were then plotted.

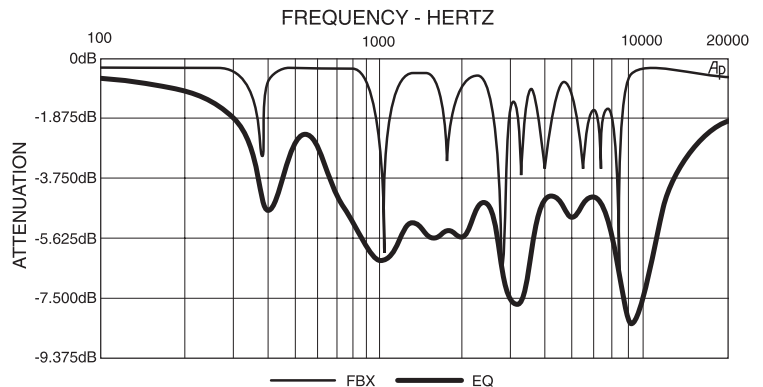

Figure 6c - FBX Filters vs Graphic EQ Filters

Note how much more of the program is eliminated using an EQ—whereas only feedback is eliminated using FBX filters.

6.2.2. Advantage #2

The second reason True Mobility™ systems are able to remove feedback while maintaining high quality audio signal is due to the placement of the signal processing in the **input chain** of the microphone signal. Many times signal processing (compression and equalization) is placed **after the output stage** of a mixer, meaning it is applied to a combination of inputs mixed together into one output and passed through the processor. Particularly in the case of equalization and feedback control, one consequence of such a signal path is that filtering applicable to just one microphone is applied to others in the same mix bus. In other words, unnecessary filtering (albeit very narrow filtering in the case of an FBX filter) may be applied to microphones that have different feedback frequencies than some of the filters set.

Placing the filtering and other signal processing in the input signal path is a concept called **Targeted Input Processing**. It means each microphone so equipped will have **customized, unique signal processing applied**—and no unneeded processing.

Sabine True Mobility Wireless Systems give you

- Targeted processing for each microphone
- Increased mobility
- Quiet, fast and easy setup of FBX filters (Our Fastest FBX setup mode!)

Constant Q vs Proportional Q Filters

Constant Q

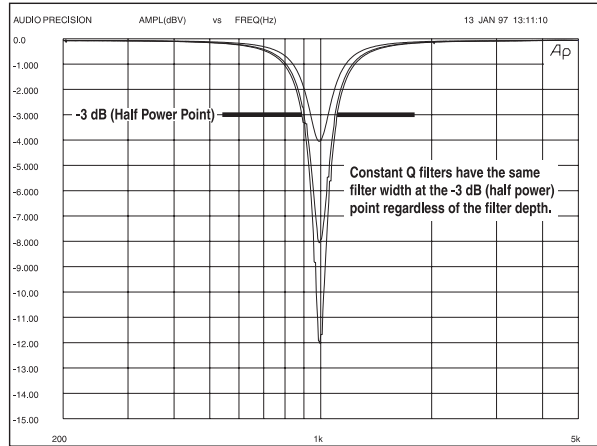

Proportional Q

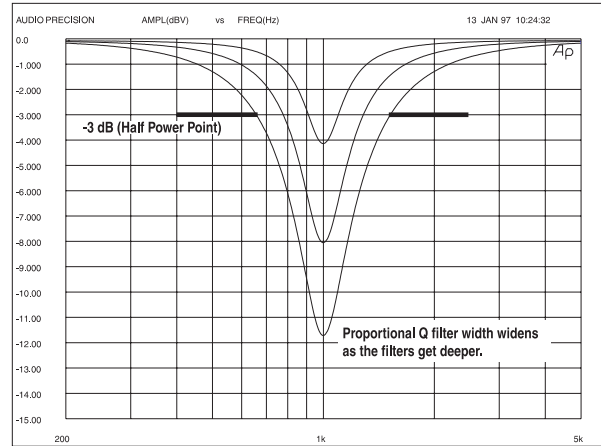

It is common to describe a filter's quality factor, or "Q," as the center frequency of the filter divided by the filter width (in Hertz) measured at the -3dB point. Filters that have the same Q, or width, at the -3dB point regardless of the filter's cut or boost are called **Constant Q** filters (see p.14, Figure 6a). Filters that get wider as the filter gets deeper are called Proportional Q filters (see p.14, Figure 6b). Lately, however, the definition of Constant Q is becoming less distinct. Many equalizer manufacturers claim their equalizers have Constant Q filters, when in fact they get substantially wider as they get deeper. The only way to know for sure if the filters are truly Constant Q is to inspect their frequency response curves. Sabine FBX Filters are true Constant Q filters.

6.3 Who Needs The FBX?

Virtually every sound system will be improved with the Sabine True Mobility™ Wireless System. Singers and speakers who do not have sound technicians can now increase their monitor or house system volume so they can hear themselves clearly and with full fidelity, without worrying if their microphone will suddenly squeal if they move to the wrong place.

Auditoriums and churches of all sizes will enjoy reliable feedback control. Hotels and conference centers around the world can offer meeting rooms with microphones that won't howl during programs. The Sabine True Mobility™ Wireless System can be installed in theaters, schools, sports arenas, courtrooms, teleconferencing, intercoms or interactive remote classrooms—anywhere one or multiple microphones are used.

6.4 FBX Setup & Ready Mode

The FBX Section has two modes: **Setup** and **Ready**. In **Setup**, the FBX filters **automatically** zero in on the most predominant feedback. Because this is a wireless system, you need to move the microphone to several areas of use during setup—this will provide maximum gain before feedback before the performance begins.

In **Ready** mode you are ready for the performance. Use the **True Mobility** as you would any wireless microphone system. The FBX section will work **automatically** to kill any additional feedback that happens to arise.

6.4.1 FBX Fixed & Dynamic filters

Here's how it's done. FBX filters come in two flavors, fixed and dynamic. **Both operate automatically.**

Fixed FBX filters: these filters will not change frequency or depth once they are placed during Setup and the receiver indicates Ready mode. These filters will eliminate the "first-to-feedback" frequencies encountered during normal system operation.

Dynamic FBX filters: these filters automatically set just like Fixed filters, except they can change frequency and depth as the need arises. Dynamic Filters stand guard if frequencies not attenuated during Setup begin to feedback during performance.

If all filters, both Dynamic and Fixed, are in place and new feedback occurs, the Dynamic filters will move to eliminate the new feedback. You never run out of filters!

6.4.2 Default FBX filter settings

The Sabine True Mobility™ Wireless System provides a total of ten filters for feedback control. The default setting makes seven of these Fixed and three Dynamic. This can be changed to eight Fixed and two Dynamic by changing an internal DIP switch position (see **Appendix 11.1 FBX Configuration DIP Switch**).

6.4.3 FBX filter width

A default setting of .10 octave has been calculated to eliminate feedback without affecting music program. If, with all filters properly set, feedback is still occurs, the FBX filters may be set to .20-octave width. This wider filter setting will help to eliminate feedback trouble areas, but may also affect music program slightly. The wider setting is generally considered to be appropriate where speech is the primary usage of the Sabine Wireless. This is to say it will not audibly affect desired program, only feedback. If the Sabine Wireless is used for music program, we recommend using the default setting of .10 octave be used. You can change FBX filter width by repositioning an internal DIP switch (see **Appendix 11.1 FBX Configuration DIP Switch**).

6.5 How To Set Up The FBX Section Of Your True Mobility™ System

Follow these steps to obtain the maximum gain and protection from feedback.

1. Place the speakers in the positions where they will be used during the program.
2. If there is any equipment with a noise gate in the signal path, you MUST DISENGAGE the noise gate(s) prior to the setup procedure. You may reengage these noise gates upon conclusion of your FBX setup.
3. Patch your Sabine receiver into the mixer or amp channel. Set the amp master output gain to a normal operating position.

NOTE: The level of your power amplifier should be set to a level that allows a healthy gain structure **prior to the amplifier**. If your amplifier is turned up fully, and your mixer meters show little movement when signal passes through, you will improve the performance of your sound system and lower system noise by reducing the gain on your power amp and increasing your mixer gain.

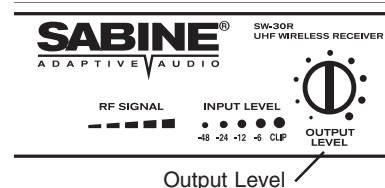

Figure 6d - Receiver Output Level

4. Turn on your wireless transmitter or handheld microphone, then the wireless receiver, then the mixer, then any other accessories, and finally the power amp. If you are using a graphic EQ, adjust only for the desired tonal qualities, but DO NOT NOTCH FOR FEEDBACK.

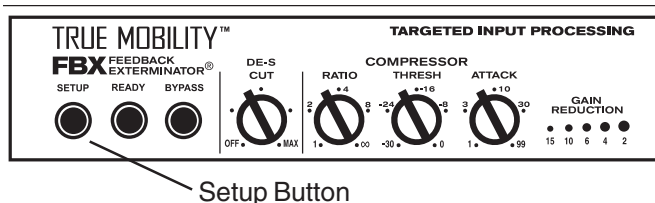

Figure 6e - FBX Setup Button

CAUTION: Do not use Sabine wireless receiver for performance while in Setup mode!

5. Now you are ready to set FBX filters. Press and hold Setup (far left button) on the wireless receiver, **until the LEDs flash four times, then release it** (the Setup LED will come on). This will clear any FBX filters already in place. **You should do this each time you move your sound system, change a sound system component, or relocate your microphone.** Your Sabine True Mobility™ Wireless System will remember its settings from the last time you turned the unit off.
6. When the Setup light comes on, your receiver is ready to set FBX filters. With the microphone turned on, raise the Output Level of the receiver **slowly** until a strong input signal at the mixer is apparent (for starters, try the 12:00 position). The microphone should now be audible.
7. During Setup mode, do not talk into the microphone or pass audio program through a transmitter. This may cause the Sabine True Mobility™ system to set inappropriate filters. **The only appropriate use of the setup mode is to create and filter feedback.**
8. **Slowly** raise the mixer channel gain to the point of feedback—and then **slowly** beyond until you hear the chirping tones of feedback quickly being eliminated by FBX filters setting. Stop raising gain after 2 or 3 feedback tones have chirped and corresponding FBX filters have set. Rest assured that any feedback that occurs will be at a quiet volume, and very short in duration.

You may quit Setup mode at any time prior to its automatic exit by simply pressing the Ready button. This will lock all fixed FBX filters, including those not set at the time of your manual exit—in other words, only the filters set at the time you pushed **Ready** will be engaged. Dynamic FBX filters will still work in the event of feedback during performance.

If you quit Setup prior to the FBX Section's automatic exit (i.e., after all fixed FBX filters are set), and later decide you need more gain before feedback (i.e., more fixed filters), you must begin the Setup process again. See Step 5 above.

9. Move the microphone to another area of use and **slowly** raise gain until FBX eliminates a few more feedback tones (2 or 3). Repeat this step until the Setup indicator automatically goes off and the Ready indicator comes on.

Any feedback that occurs after setup will be eliminated by Dynamic filters. In most instances you will experience an additional gain of 6-9 dB before feedback when using the Sabine True Mobility™ System. Precise results will depend on system and acoustical considerations.

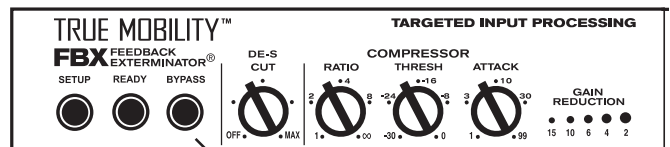

Bypass Button
Figure 6f - FBX Section Bypass Button

All fixed filters in place will remain set until the Setup button is pushed and held as described in step 5. All dynamic filters will remain in place until new feedback occurs (wherein they will move to the new frequency), or until the Setup button is pushed and held.

6.6 Bypass Button

The Bypass button bypasses only the FBX Section, and not the additional signal processing (de-essing and compression) available in the Targeted Input Processing section of the Sabine True Mobility™ Wireless Receiver.

SECTION SEVEN : DE-ESSER SET UP

7.1 The Essence of De-essing

Certain consonant sounds produced by the human voice have the potential to overload a microphone capsule, and to end up as disproportionately harsh and loud when amplified through a sound system, and/or recorded to analog or digital storage media. The most common and obvious of these sounds is the “ssss” sound, associated with pronunciation of both “s” and soft “c” consonants in many languages, and also the consonants “t,” “f,” and sometimes “d.” The technical term for this particular vocal sound is “sibilance,” and the devices which control such sounds are typically called “de-essers” (or sometimes sibilance controllers). The frequency range of sibilance will vary depending on the singer/speaker, the consonant involved, the orientation to the microphone, the microphone itself, and the normal variations in human vocalization. The range of frequencies affected by sibilance starts above 2.5 KHz, and generally tapers off above 10 KHz.

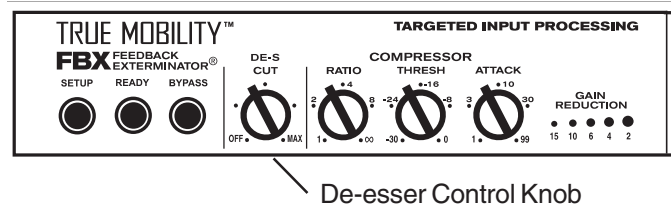

Figure 7a - De-esser Control Knob

The Sabine De-Esser is a type of compressor that operates at frequencies between 2.5 KHz and 12 KHz. The De-Esser reduces the amplitude of vocal sibilant sounds which may become apparent when a singer or speaker gets too close to the microphone. When the energy level of high-frequency sounds exceeds a preset threshold, the de-esser reduces the high frequency response for the length of time the threshold is exceeded. High frequency energy below the threshold will not be affected by the de-esser. Low energy level, high frequency sounds also are not affected.

7.1.1 The True Mobility De-esser

The Sabine De-Esser is a type of compressor that operates at frequencies between 2.5 KHz and 12 KHz. The De-Esser reduces the amplitude of vocal sibilant sounds which may become apparent when a singer or speaker gets too close to the microphone. When the energy level of high-frequency sounds exceeds a preset threshold, the de-esser reduces the high frequency response for the length of time the threshold is exceeded. High frequency energy below the threshold will not be affected by the de-esser. Low energy level, high frequency sounds also are not affected.

7.2 Using the De-esser

The Sabine De-Esser is simple to use. The fully counterclockwise position is OFF. From that point, **the more you turn the knob clockwise, the more sibilance is reduced from your program.**

Sabine De-Esser can be used to compensate for varying sibilance levels due to placement of lavalier microphones (the closer the lavalier microphone is to the user’s mouth, the greater is the **potential** for audible sibilance).

SECTION EIGHT : COMPRESSOR SET UP

8.1 Basics of Compression

The dynamic range (how loud we can hear to how quiet a sound we can detect) of the human ear is far greater than the capacity of sound systems to reproduce. Although some of this equipment limitation is at the upper extreme of the dynamic range (where too loud a signal will produce distortion), much of the restriction occurs at the low level end, where the signal disappears below the “noise floor” of the circuitry.

A compressor (or in its most powerful form, a limiter) is the most widely used tool for controlling dynamic range. In the simplest terms, a compressor is designed to squeeze the dynamic range of an audio program; i.e., to make quiet signals louder, and loud signals quieter. A compressor becomes a limiter when the compression ratio (the ratio of the input gain change to the output gain change) is so high that the output level won't rise above a “brick wall” ceiling regardless of how loud the input gets (typically 10:1 and greater).

A compressor acts like an “automatic mix engineer” with a hand on the fader and an inhumanly fast reaction time. When the input level increases, the engineer drops the fader; when the level decreases, the fader is raised. When the amount of fader compensation equals the variation in signal level, the output level of the audio program will sound consistent.

The practical benefits of compression and limiting include:

1. **Speaker protection.** A compressor will control sudden level peaks and prevent your speakers from damage.
2. **Perceived increase in loudness.** Because peak levels are kept from rising as high as uncompressed signals, you gain headroom for your audio program and can raise its overall average gain. Compression is often added to the entire audio mix, both in live sound and recording, to increase its perceived loudness.
3. **Consistent Level.** For expressive instruments or vocals, which may have a large dynamic range, compression can help maintain consistent mix levels. So a speaker who varies from a whisper to a shout will not disappear or stand out in the mix, relative to other less dynamic instruments.

8.2 Using the Compressor

Compressor controls are located immediately to the right of the FBX and De-esser panels. The controls consist of standard **Ratio**, **Thresh** (threshold), and **Attack** knobs, and a horizontal LED ladder showing compressor gain reduction.

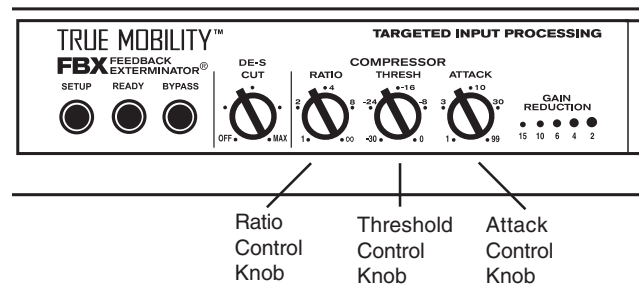

Figure 8a - Compressor Section

- Ratio:** Compression ratio is the ratio of the input gain change to the output gain change. The compression ratio on your Sabine Wireless ranges from 1:1 to infinity:1 (limiting).
- Thresh:** Compression threshold is the level at which the compressor/limiter begins to act on the signal. The input level threshold at which compression is engaged can be adjusted from -30 dBV to 0 dBV.
- Attack:** Compressor attack time is the time it takes to compress after a strong signal reaches the threshold level.

NOTE 1 : Use the mixer channel or amp gain for gain make-up after compression.

NOTE 2 : Default Release Time for the True Mobility Compressor is 400 mSec with the Knee set to Soft.

8.3 Suggested Compressor Settings

8.3.1 Vocal Compression

The renowned expressiveness of the human voice is due in large part to its dynamics. A vocal that varies from a whisper to a scream has a strong emotional impact, but those same dynamics present a challenge to the sound engineer. Ideal vocal compression maintains some dynamic range while keeping the vocal the focal point of the mix.

Ratio: A soft voice might require a ratio of 2:1, whereas a loud voice might require a ratio setting of 6:1.

Thresh: The higher the threshold setting, the more signal required to initiate compression.

Attack: Short attack.

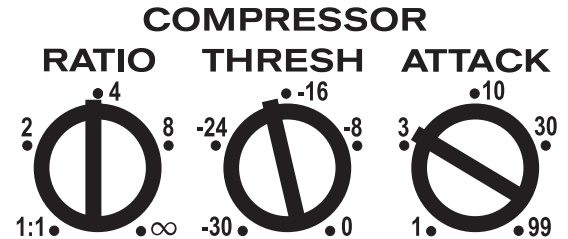

Figure 8b

(Ratio set to from 2 to 6:1; threshold set so vocal peaks are compressed about 4-6 dB, attack should be fairly quick).

8.3.2 Guitar Compression

A high compression (with gain makeup) will add sustain to held notes and chords. Moving the threshold will change the audible thick/thinness of the guitar tone, but generally you want to compress all the notes played. Be wary of too quick an attack, which may reduce the percussive attack of the guitar notes. In general, use a longer attack for instruments. Be wary of too high a compression ratio, which may make a noisy guitar amplifier more objectionable.

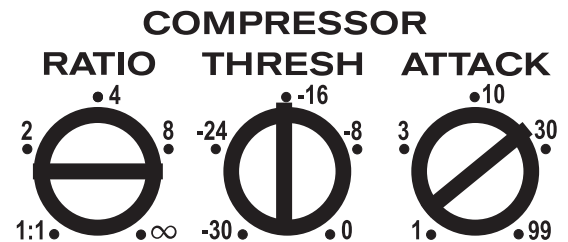
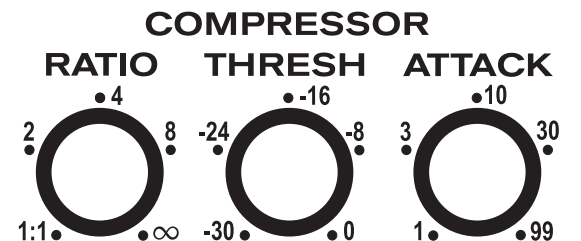
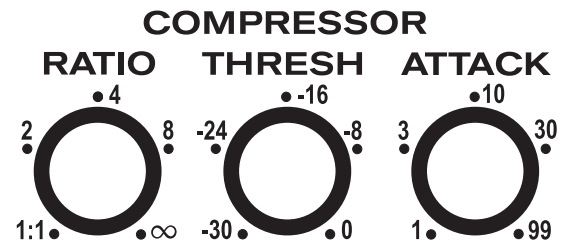

Figure 8c

(Ratio set from 6 to 20:1, threshold variable, slower attack.)

8.3.2 Additional Settings

For your own recall, draw in any settings and their use that you have discovered.



8.4 Possible Compression Trouble Areas

Like any signal processing, compression can be misused, and cause undesirable problems in the audio signal. Some of these problems include:

1. **Noise.** If the threshold for compression is set too low, and the output gain is raised substantially to make up for the gain loss of compression, the resulting output signal can be noisy. This is because the input signal must be raised significantly to produce the same output level, and the noise floor of your equipment will be amplified unnecessarily. This problem will be exaggerated if the input signal level to the compressor is very low (which will already degrade the signal-to-noise ratio).
2. **Breathing.** In situations where the compression ratio is high, the threshold is low, and the release time of the compressor is short, the noise floor will modulate up and down as the audio signal stops and starts.
3. **Over-compression.** Applying too much compression to a mix can sometimes result in such evened-out dynamics that the “life” of the music has been removed or curtailed. Dynamic variation in music is a major component of its excitement and interest; don’t remove them, just control them. This may be particularly true for percussive sounds such as drums.

SECTION NINE : TIPS AND TROUBLESHOOTING

9.1 Tips for Maximum Performance of your True Mobility Wireless System

- Keep a clear and unobstructed path between transmitter and receiver.
- Position receiver antennas at least one meter off the performance floor level.
- Avoid placing receiver antennas near large metallic or other dense materials.
- Keep receiver antennas away from RF signal generating equipment (computers, high-voltage equipment, etc.).
- If the receiver is rack mounted, you can use the Sabine SWA100 Rear to Front Antenna Converter Kit or one of the Extension Antenna kits (UHF systems: SWAUEXT; VHF systems: SWAVEXT) to improve RF performance.
- Position antennas perpendicular to each other.
- Use a Sabine Antenna Divider System (SWA4U, SWA4V) for multiple system installation.
NOTE: It is highly recommended that SWAUB Antenna Boosters be used with the Antenna Divider System. The Antenna Boosters will boost the signal +13dB. Placement of the Divider more than 10 meters from the receiver positively requires the use of Antenna Boosters.
- Keep two extra Sabine Rechargeable 9-volt NiMH batteries charging in the on-board, dual battery charger.

9.2 Troubleshooting

Problem: True Mobility receiver and transmitter power are on, receiver RF Signal LEDs and Input Level LEDs are lighting up, but no sound from system.

Solution: Check connection between receiver and mixer/amp. Adjust receiver Output Level control.

Problem: True Mobility receiver and transmitter power are on, but receiver RF Signal LEDs and Input Level LEDs are not lighting up.

Solution: Check transmitter On/Battery Indicator. Replace weak battery with fresh battery from charger unit if necessary. Check transmitter and receiver frequency Group/Channel settings (make sure they match). Check receiver squelch setting. Check receiver antenna connections. Check distance between transmitter and receiver antennas and possible obstructions in path.

Problem: Transmitter is on, but sound is noisy.

Solution: Check transmitter On/Battery Indicator. Replace weak battery with fresh battery from charger unit if necessary. Check for other sources of RF interference (high voltage equipment, lighting equipment, etc.). If using multiple units, make sure that all units are set to different frequencies within their allotted group. Do not mix groups unless so stated in Section Ten. Check distance between transmitters and receiver antennas.

Problem: Transmitter is off, but noise still coming from receiver.

Solution: Adjust receiver squelch control. Check for other sources of RF interference (high voltage equipment, lighting equipment, trolley cars, etc.). Select another frequency. Check connection and position of the receiver antennas. Utilize a Sabine Extension Antenna and/or Extension Antenna Booster (Extension Antenna Booster requires the use of a Sabine Antenna Divider).

SECTION TEN : MULTIPLE FREQUENCY & USE CHARTS

10.1 UHF Frequency Code U3 [USA]

SWM-3000 UHF transmitters and receivers have both Group and Channel selector knobs. The channels within each group have been arranged so that you can use up to 14 wireless units at a single location without having the units interfere with each other.

In general, use channels from within the same group to avoid interference. For maximum number of units, see Example #2 below.

EXAMPLE: The 8 channels within group 1 are all compatible. To use 8 UHF units at a single location, set the receivers and transmitters as follows:

Transmitter/Receiver	GROUP	CHANNEL
unit #1	1	1
unit #2	1	2
unit #3	1	3
unit #4	1	4
unit #5	1	5
unit #6	1	6
unit #7	1	7
unit #8	1	8

EXAMPLE: To use the maximum number of 14 units together, use all 7 channels of GROUP 3, plus all 7 channels of GROUP 4.

NOTE : To avoid intermodulation distortion (IMD) interference, all transmitters must be kept at least 5 meters from any True Mobility UHF receiver antenna.

Frequencies in USA 900 MHz UHF Systems

GROUP	CHANNEL (MHZ)								Minimum distance to receiver
	1	2	3	4	5	6	7	8	
1	914.275	914.900	916.375	916.725	920.200	921.200	926.800	929.875	3m
2	915.150	916.125	917.925	922.650	924.075	924.775	928.125	928.500	
3	914.250	915.475	918.275	919.450	925.575	926.650	929.150		5m
4	915.075	917.875	919.050	925.225	926.300	928.750	929.925		

Guide to new/old Frequency Code designations

U1 = U794A (786.275 - 801.925)	U3 = U922A (904.275 - 928.5)
U2 = U808C (802.675 - 815.95)	
V1 = VND1 (200.35 - 202.6)	V3 = VPD2 (202.25 - 204.5)
V2 = VND2 (201.75 - 204.0)	V4 = VPE4 (215.2 - 217.45)
	V5 = VPH5 (247.05 - 249.3)
	V6 = VPH4 (245.8 - 248.05)

Section Ten : Multiple Frequency & Use Charts

10.2 UHF Frequency Code U2 [Export]

SWM-3000 UHF transmitters and receivers have both Group and Channel selector knobs. The channels within each group have been arranged so that you can use up to 10 wireless units at a single location without having the units interfere with each other.

In general, use channels from within the same group to avoid interference (Group 6 is an exception, see NOTE 2 below). For the maximum number of units, refer to EXAMPLE #2 below.

EXAMPLE 1: The 6 channels within Group 1 are all compatible with each other. To use six UHF units at a single location, set the receiver and transmitter as follows:

Transmitter/Receiver	GROUP	CHANNEL
unit #1	1	1
unit #2	1	2
unit #3	1	3
unit #4	1	4
unit #5	1	5
unit #6	1	6

EXAMPLE 2: To use the maximum number of 10 units together, use all six channels of U2 Group 4, plus the following 4 additional channels from U2 Groups 1-5 :

Transmitter/Receiver	GROUP	CHANNEL
unit #7	1	5
unit #8	3	1
unit #9	5	1
unit #10	6	3

NOTE 1: To avoid intermodulation distortion (IMD) interference, all transmitters must be kept at least 6 meters from any True Mobility UHF receiver antenna.

NOTE 2: The three channels in U2 Group 6 are not compatible with each other and may cause interference. Do not use these frequencies together as a group.

UHF Frequency Code U2: 802.675 - 815.950 MHz

	CHANNEL (MHZ)						Minimum distance to receiver	
	1	2	3	4	5	6		
GROUP	1	802.675	804.250	806.175	808.450	811.075	814.675	5m
	2	802.325	803.900	805.825	808.100	810.725	814.325	
3	801.000	802.875	805.175	807.900	811.050	815.600	3m	
4	800.600	802.475	804.775	807.500	810.650	815.200		
5	803.250	809.250	813.250				1m	
6	800.250	808.450	815.950					

10.3 UHF Frequency Code U1 [Export]

SWM-3000 UHF transmitters and receivers have both Group and Channel selector knobs. The channels within each group have been arranged so that you can use up to 10 wireless units at a single location without having the units interfere with each other.

In general, use channels from within the same group to avoid interference. For maximum number of units, see Example #2 on page 29.

EXAMPLE 1: The 8 channels within group 1 are all compatible with each other. To use 8 UHF units at a single location, set the receivers and transmitters as follows:

Transmitter/Receiver	GROUP	CHANNEL
unit #1	1	1
unit #2	1	2
unit #3	1	3
unit #4	1	4
unit #5	1	5
unit #6	1	6
unit #7	1	7
unit #8	1	8

EXAMPLE 2: To use the maximum number of 14 units together, use all 7 channels of Group 3, plus all 7 channels of Group 4.

NOTE : To avoid intermodulation distortion (IMD) interference, all transmitters must be kept at least 5 meters from any True Mobility UHF receiver antenna.

UHF Frequency Code U1: 786.275 - 801.925 MHz

GROUP	CHANNEL (MHZ)								Minimum distance to receiver
	1	2	3	4	5	6	7	8	
1	786.275	786.900	788.375	788.725	792.200	793.200	798.800	801.875	3m
2	787.150	788.125	789.925	794.650	796.075	796.775	800.125	800.500	
3	786.250	787.475	790.275	791.450	797.575	798.650	801.150	5m	
4	787.075	789.875	791.050	797.225	798.300	800.750	801.925		

10.4 VHF Frequencies [USA]

The following frequencies are offered for the USA market. Refer to the Frequency Group Code on your Sabine SWM-1600 VHF receiver.

V1 200.350~202.600 MHz (TV Channel 11 - 198~204MHz)

Ch.1	Ch.2	Ch.3	Ch.4	Ch.5	Ch.6	Ch.7	Ch.8
200.35	200.65	200.95	201.25	200.5	200.8	201.1	201.4
Ch.9	Ch.10	Ch.11	Ch.12	Ch.13	Ch.14	Ch.15	Ch.16
201.7	202	202.3	202.6	201.55	201.85	202.15	202.45

V2 201.750 - 204.000 MHz (TV Channel 11 - 198~204MHz)

Ch.1	Ch.2	Ch.3	Ch.4	Ch.5	Ch.6	Ch.7	Ch.8
201.75	202.05	202.35	202.65	201.9	202.2	202.5	202.8
Ch.9	Ch.10	Ch.11	Ch.12	Ch.13	Ch.14	Ch.15	Ch.16
203.1	203.4	203.7	204	202.95	203.25	203.55	203.85

NOTE 1: Up to 3 VHF systems can be used simultaneously for each group of 16 frequencies. **For use of up to six systems, use 3 systems from one group and 3 from the other group. For best results, use consecutive channels starting from channel 1.**

NOTE 2: If TV channel 11 is used for broadcast in your area, we do not recommend using the VHF channels — use UHF instead.

Guide to new/old Frequency Code designations

U1 = U794A (786.275 - 801.925)	U3 = U922A (904.275 - 928.5)
U2 = U808C (802.675 - 815.95)	
V1 = VND1 (200.35 - 202.6)	V3 = VPD2 (202.25 - 204.5)
V2 = VND2 (201.75 - 204.0)	V4 = VPE4 (215.2 - 217.45)
	V5 = VPH5 (247.05 - 249.3)
	V6 = VPH4 (245.8 - 248.05)

10.5 VHF Frequencies [Export]

The following frequencies are offered for the export market. NOTE: Frequencies offered are subject to change. Please consult the back of your VHF receiver for the frequency group number and frequency chart.

V3 202.250 - 204.500 MHz *

Ch.1 202.25	Ch.2 202.55	Ch.3 202.85	Ch.4 203.15	Ch.5 202.4	Ch.6 202.7	Ch.7 203	Ch.8 203.3
Ch.9 203.6	Ch.10 203.9	Ch.11 204.2	Ch.12 204.5	Ch.13 203.45	Ch.14 203.75	Ch.15 204.05	Ch.16 204.35

V4 215.200 - 217.450 MHz *

Ch.1 215.2	Ch.2 215.5	Ch.3 215.8	Ch.4 216.1	Ch.5 215.35	Ch.6 215.65	Ch.7 215.95	Ch.8 216.25
Ch.9 216.55	Ch.10 216.85	Ch.11 217.15	Ch.12 217.45	Ch.13 216.4	Ch.14 216.7	Ch.15 217	Ch.16 217.3

V6 245.800 - 248.050 MHz *

Ch.1 245.8	Ch.2 246.1	Ch.3 246.4	Ch.4 246.7	Ch.5 245.95	Ch.6 246.25	Ch.7 246.55	Ch.8 246.85
Ch.9 247.15	Ch.10 247.45	Ch.11 247.75	Ch.12 248.05	Ch.13 247	Ch.14 247.3	Ch.15 247.6	Ch.16 247.9

V5 247.050 - 249.300 MHz *

Ch.1 247.05	Ch.2 247.35	Ch.3 247.65	Ch.4 247.95	Ch.5 247.2	Ch.6 247.5	Ch.7 247.8	Ch.8 248.1
Ch.9 248.4	Ch.10 248.7	Ch.11 249	Ch.12 249.3	Ch.13 248.25	Ch.14 248.55	Ch.15 248.85	Ch.16 249.15

*** NOTE: Up to 3 VHF systems can be used simultaneously for each group of 16 frequencies. For use up to six systems, use 3 systems from one group and 3 from another group.**

For best results, use consecutive channels starting from channel 1.

Guide to new/old Frequency Code designations

THC	U1 = U794A (786.275 - 801.925) U3 = U922A (904.275 - 928.5) U2 = U808C (802.675 - 815.95)
THV	V1 = VND1 (200.35 - 202.6) V3 = VPD2 (202.25 - 204.5) V5 = VPH5 (247.05 - 249.3) V2 = VND2 (201.75 - 204.0) V4 = VPE4 (215.2 - 217.45) V6 = VPH4 (245.8 - 248.05)

SECTION ELEVEN : APPENDICES

11.1 FBX Configuration DIP Switch

WARNING: ELECTRIC SHOCK HAZARD! UNPLUG receiver BEFORE taking off top cover! Serious injury or death may result if unit is opened/worked on while plugged in. These procedures are to be performed by qualified personnel only.

Refer to **Section 6.5 How to Set Up the FBX Section of Your True Mobility System** for a description of Fixed versus Dynamic FBX Filters.

1. Remove receiver top cover

Take out four screws on each side and two from the top of the back panel. Sort and save all screws. Lift the back of the top cover, and then pull until the edge of the top cover (and three tabs) emerge from under the front panel plastic rim.

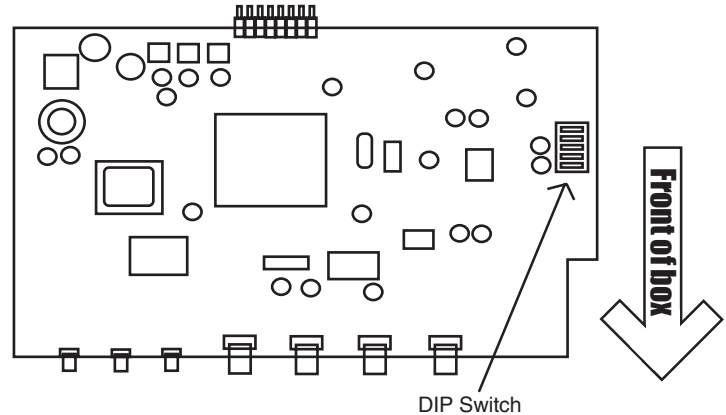

Figure 11a - FBX Configuration DIP Switch

2. Change DIP switch settings

There are two PC boards inside the receiver. With the front of the unit facing you, the left and smaller board (Figure 11a) has a DIP switch in the middle of the right hand side. The DIP switch is covered with a translucent piece of yellow plastic wrap. Pull off the wrap (it cannot be reused). Note that there are five switches. One side of the DIP switch is clearly marked ON. The factory default setting is with all switches set to ON (see Figure 11b).

Refer to Figure 11c to set the number of Fixed and Dynamic filters to 8 Fixed and 2 Dynamic and Figure 11d to widen the filter width to .20 (1/5) octave. These options can be combined to produce 8 Fixed and 2 Dynamic 1/5-octave filters by pushing switch numbers 1 and 2 to the OFF position (Figure 11e). Refer to **Section 6.5** for a complete understanding of these options.

3. Replace top cover

Align and insert the three front tabs under the front panel plastic rim, then lower the back of the cover. Replace all screws. **DO NOT FORCE** screws. If they do not go in easily, adjust cover alignment and try again.

Default setting

7 Fixed, 3 Dynamic
One-tenth Octave

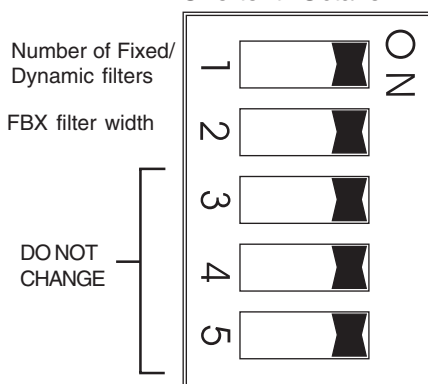

Figure 11b

More Fixed filters

8 Fixed, 2 Dynamic,
One-tenth Octave

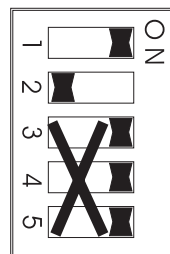

Figure 11c

Wider FBX filters

7 Fixed, 3 Dynamic
One-fifth Octave,

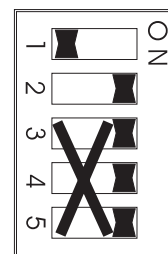

Figure 11d

Both

8 Fixed, 2 Dynamic,
One-fifth Octave

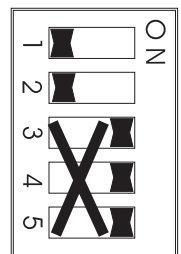
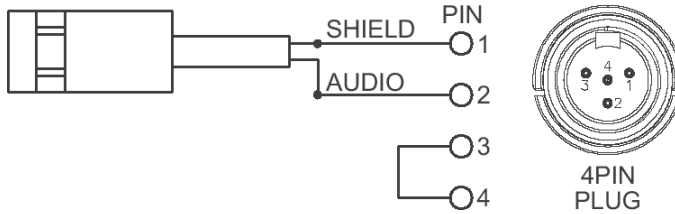

Figure 11e

WARNING: Do not change switch 3, 4 or 5 from the default ON setting!

11.2 Beltpack Transmitter Connector Wiring Diagrams

Two-wire electret condenser microphone capsule



Three-wire electret condenser microphone capsule

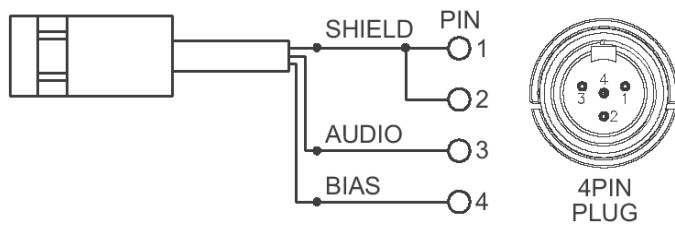

Dynamic microphone

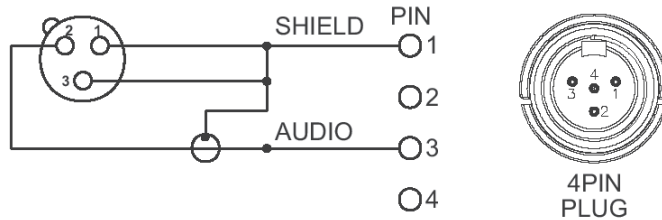

Electric guitar

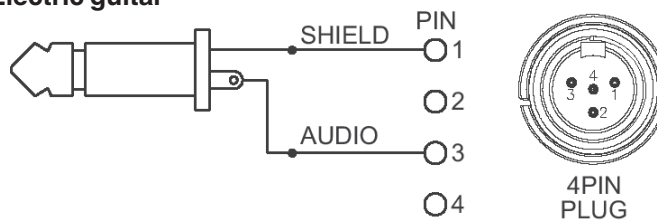

Line-in (impedance 8K ohm ATT. 10 dB)

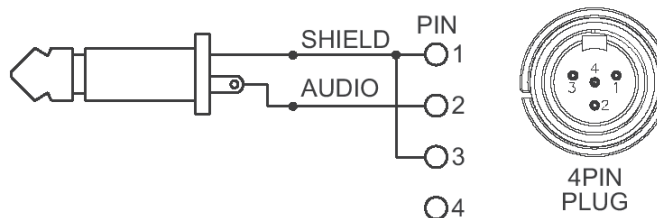

11.3 XLR Connector



1. Shield
2. Positive
3. Negative

11.4 Beltpack Transmitter Schematic

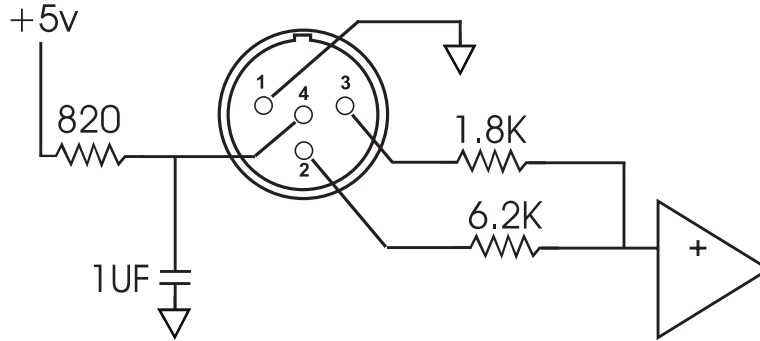

11.5 Engineering Specifications**SW30-R UHF Receiver**

Carrier Frequency Range: UHF Band 794-930 MHz
Frequencies: 30 pre-programmed
Oscillation Mode: PLL synthesized
Receiving Mode: True diversity
Sensitivity: 6 dBV at S/N over 70 dB
Image Rejection: >63 dB
Spurious Rejection: >76 dB
Stability: +/- 0.005%
Maximum Deviation: +/- 40 KHz
Dynamic Range: >100 dB
S/N Ratio: 95 dB (Typical) ¹
THD: <0.3%
Squelch: Sabine two-stage
Squelch Quieting: 6-30 dB
Frequency Response: 50 Hz-18 KHz +/- 3 dB
Output Configuration (mic level):
 1/4 inch connector, unbalanced
 XLR connector, balanced
Nominal Audio Output Level: 1 dBV, with 20 dB headroom
Battery Charger: Built-in dual slot
Antennas: 2, 3/4 λ
Power Supply: 12-15 VDC/100-240 VAC 50-60 Hz
Rack-Mountable case, (1U with rack mount ears)
Working Range: 100 meters

SW16-R VHF Receiver

Carrier Frequency Range: VHF Band 160-250 MHz
Frequencies: 16 pre-programmed
Oscillation Mode: PLL synthesized
Receiving Mode: True diversity
Stability: +/- 0.005%
Sensitivity: 10 dBV at S/N over 80 dB
Image Rejection: >63 dB
Spurious Rejection: >76 dB
Maximum Deviation: +/- 30 KHz
Dynamic Range: >100 dB
S/N Ratio: >95 dB (Typical) ¹
THD: <0.3%
Squelch: Sabine two-stage
Squelch Quieting: 12-40 dB
Frequency Response: 50 Hz-18 KHz +/- 3 dB
Output Configuration (mic level):
 1/4 inch connector, unbalanced ²
 XLR connector, balanced
Nominal Audio Output Level: 0.5 dBV, with 20 dB headroom ³
Battery Charger: Built-in dual slot
Antennas: 2, 1/4 λ
Power Supply: 12-15 VDC/100-240 VAC 50-60 Hz
Rack-Mountable case, 1U (with rack mount ears)
Working Range: 100 meters

Handheld Microphone

Element: Condenser
Antenna: Built-in
FM Deviation: 30 KHz for VHF, 40 KHz for UHF
RF Frequency Stability: +/- 0.005%
RF Output: 2 mW ERP maximum
Spurious output: < 4 nW
Dimensions: 9.6875 in. x (1.95 in to 1.49 in)
Battery: One 9V (or Sabine Rechargeable)
Battery Life: 500 charge cycles

Lavalier Microphone

Transducer type: Electret condenser
Frequency Response: 50 Hz to 19,000Hz
Directional Characteristic: Uni-Directional
Sensitivity: -46 dB \pm 3 dB at 1KHz (0db = 1V/Pa)
Maximum Sound Pressure: 140 dB SPL
Output Impedance: 2K Ω
Equivalent Acoustic Noise: 27 dB SPL A-Weighted
Power Requirements: Regulated nominal +5Vdc (@ 220uA)
source provided at microphone connector pin #4 relative to pin #1 of a Sabine True Mobility wireless beltpack transmitter.
Weight: 18 g
Dimensions: 11 x 26.8 mm

UHF BeltPack Transmitter

FM Deviation: 40 KHz
RF Frequency Stability: +/- 0.005%
Spurious output: < 4 nW
RF Output: 10 mW ERP maximum
Audio gain: 0-30 dB
Mic input impedance: 470 K Ohms
Mic bias: 5V
Mic connector: 4-pin
Antenna type: 1/4 λ , (3.42 in., rigid wire type)
Dimensions: 4.02 in. x 1.24 in x 2.49 in.
Battery: One 9V (or Sabine Rechargeable)
Battery Life: 500 charge cycles

VHF BeltPack Transmitter

FM Deviation: 30 KHz
RF Frequency Stability: +/- 0.005%
Spurious output: < 4 nW
RF Output: 10 mW ERP maximum
Audio gain: 0-30 dB
Mic bias: 5V
Mic input impedance: 470 K Ohms
Mic connector: 4-pin
Antenna type: self contained
Dimensions: 4.02 in. x 1.24 in x 2.49 in.
Battery: One 9V (or Sabine Rechargeable)
Battery Life: 500 charge cycles

SWA4U UHF Antenna Divider

Filter Bandwidth: 750~960 MHz +/- 3 dB
3rd Order Interception: (+) 22 dBm
Noise Figure: < 3.7 dB (Center Band)
Input/Output Gain: (+) 1.6dB (Center Band)
Output Port Isolation: 32 dB minimum
Connector: TNC type
Power Supply: DC 12~18 V
Current Drain: < 176 mA

SWA4V VHF Antenna Divider

Filter Bandwidth: 165-250 MHz +/- 3 dB
3rd Order Interception: (+) 35.5 dBm
Noise Figure: < 6dB (Center Band)
Input/Output Gain: (+) 1dB (Center Band)
Output Port Isolation: 16 dB minimum
Connector: TNC type
Power Supply: DC 12-18 V
Current Drain: < 148 mA

FBX Filters

Ten independent digital filters per channel, controlled automatically from 20 Hz to 20 KHz
Filter depth: 3 dB steps from 0 dB to -40 dB
Filter width: .1 or .2 octave ⁴
Resolution: 1 Hz from 20 Hz to 20 KHz
Time required to find and eliminate feedback: typically 0.3 seconds @ 1 KHz

Digital Compressor

Threshold: -30 dB to 0 dB
Ratio: 1:1 through infinity
Knee: soft
Attack: 1-99 mSec
Release: 400 mSec

Automatic De-Esser

Cut range: 0 to -30 dB

Mechanical

Dimensions: 1U rack mount, 19 x 1.75 x 9 in. (48.3 x 4.5 x 21.6 cm)
Weight: 5.3 lb. (2.4 kg.)

¹ Signal-to-noise ratio is the ratio of the maximum undistorted signal by specification (26 dBV RMS sinewave) to the noise floor.

² See page 12, NOTE 1 for Level Switch affect on 1/4 inch unbalanced output.

³ Nominal Audio Output Level plus headroom equals clip level.

⁴ Below approximately 200 Hz the feedback filters become slightly wider to increase the feedback and rumble capture speed at these low frequencies.

(SPECIFICATIONS SUBJECT TO CHANGE WITHOUT NOTICE)

One-year limited warranty
 Patented

Compliance Statement for European RTTE Directive 1999/5/EC

In accordance with RTTE Directive 1999/5/EC, which took effect on April 8, 2000, for most countries in Europe, Sabine Inc. hereby certifies the following to apply for all models of the Sabine True Mobility™ Wireless Microphone systems and components:

1. All systems and components conform to the directives outlined in RTTE Directive 1999/5/EC, and to standards ETS 300 445, ETS 300 422, EN 50081-1, and EN 50082-1, as applicable.
2. As of April 8, 2000, these products have been or will be placed on the market in the following European countries: Germany, Norway, Spain, Italy, Switzerland, Belgium, Czech Republic, Russia, Greece, Denmark, and Iceland.
3. All Sabine True Mobility™ equipment bears the CE mark. In addition to Sabine's manufacturer's statement of conformity, compliance and conformity testing has been performed and certified by Electronic Technology Systems (ETS) of Germany, DAR registration number BPT-ZE-026/96-00.
4. Because radio frequency allocations have not yet been fully harmonized within the European Union, or across Europe as a whole, all Sabine True Mobility™ transmitters display a "warning sign" to indicate these products are considered "Class 2" products under the terms of RTTE Directive 1999/5/EC.

CAUTION - Implanted cardiac pacemakers or AICD devices:

Any source of RF (radio frequency) energy may interfere with normal functioning of the implanted device. All wireless microphones have low-power transmitters (less than 0.05 watts output) that are unlikely to cause difficulty, especially if they are at least a few inches away. However, since a beltpack transmitter typically is placed against the body, Sabine suggests at-

taching it at the belt, rather than in a shirt pocket where it may be immediately adjacent to an implanted medical device. Note also that any medical-device disruption will cease when the RF transmitting source is turned off. Please contact your physician or medical-device provider if you have any questions, or experience any problems with the use of this or any other RF equipment.

SECTION TWELVE : CAUTIONS & WARRANTY

Warning! This equipment must be earthed.

Caution! Risk of electric shock. Do not open.

Caution! Shock hazard. Do not remove covers. No user serviceable parts inside. Refer servicing to qualified service personnel.

Warning! To reduce the risk of fire or electric shock, do not expose this product to rain or moisture.

Attention! Cet appareil doit être relié à la terre.

Attention! Risque de choc électrique; ne pas ouvrir.

Attention! Risque de choc; ne pas ôter les capots. Aucune pièce accessible à l'intérieur. S'adresser à un technicien qualifié.

Attention! Pour réduire le risque d'incendie ou de choc électrique, ne pas laisser l'appareil sous la pluie ou à l'humidité.

Achtung! Dieses Gerät muss schutzgeerdet sein.

Achtung! Gefahr eines elektrischen Stromschlags. Gehäuse nicht öffnen.

Achtung! Gefahr eines elektrischen Stromschlags. Gehäuse nicht öffnen. Keine von Benutzer zu bedienenden Teile im Geräteinneren.

Überlassen Sie das Gerät zu Servicezwecken nur geschultem Fachpersonal. Um Brandgefahr oder das Risiko eines elektrischen Schlags auszuschließen, das Gerät vor Nässe und Feuchtigkeit schützen.

Advertencia! Este equipo debe estar conectado a tierra.

Precaución! Riesgo de descarga eléctrica. No abrir.

Precaución! Riesgo de descarga eléctrica. No desmontar las tapas. Piezas interiores no reparables por el usuario. Reparable sólo por personal cualificado. Advertencia! Para reducir el riesgo de incendio o de descarga eléctrica no exponga este producto a la lluvia o humedad.

FCC Statement:

This device complies with Part 15, Class B, of the FCC Rules. Operation is subject to the following conditions: (1) This device may not cause harmful interference; and (2) This device must accept any interference received, including interference that may cause undesired operation. *Warning:* Changes or modifications to this unit not expressly approved by the party responsible for compliance could void the user's authority to operate the equipment.

NOTE: This equipment has been tested and found to comply with the limits for a Class B digital device, pursuant to Part 15 of the FCC Rules. These limits are designed to provide reasonable protection against harmful interference in a residential installation. This equipment generates, uses, and can radiate radio frequency energy and, if not installed and used in accordance with the instructions, may cause harmful interference to radio communications. However, there is no guarantee that interference will not occur in a particular installation. If this equipment does cause harmful interference to radio or television reception, which can be determined by turning the equipment off and on, the user is encouraged to try to correct the interference by one or more of the following measures:

- Reorient or relocate the receiving antenna.
- Increase the separation between the equipment and receiver.
- Connect the equipment into an outlet on a circuit different from that to which the receiver is connected.
- Consult the dealer or an experienced radio TV technician for help.

Canadian Compliance Statement

This digital apparatus does not exceed the Class B limits for radio noise emissions from digital apparatus set out in the Radio Interference Regulations of the Canadian Department of Communications.

Le présent appareil numérique n'émet pas de bruits radioélectriques dépassant les limites applicables aux appareils numériques de la class B prescrites dans le Règlement sur le brouillage radioélectrique édicté par le ministère des Communications du Canada.

Japanese EMI Compliance Statement

この装置は、第二種情報装置（住宅地域又はその隣接した地域において使用されるべき情報装置）で住宅地域での電波障害防止を目的とした情報処理装置等電波障害自主規制協議会（VCCI）基準に適合しております。しかし、本装置をラジオ、テレビジョン受信機に近接してご使用になると、受信障害の原因となることがあります。取扱説明書に従って正しい取り扱いをして下さい。



Warning!



The True Mobility is designed to operate from standard AC power. Please be sure the power in your area is compatible with the power requirements marked on the rear of the unit. Using the wrong input voltage may cause permanent damage to the unit and will void the warranty.

The True Mobility Wireless Microphone system is supplied with one of the following AC power cords:

Japan	100 VAC
U.S./North America	120 VAC
Continental Europe	230 VAC
United Kingdom	240 VAC
Australia	240 VAC



Battery Caution!



DO NOT BURN OR PUNCTURE BATTERY. DOING SO COULD RELEASE TOXIC MATERIALS WHICH COULD CAUSE INJURY. DO NOT SHORT CIRCUIT

MUST BE RECYCLED OR DISPOSED OF PROPERLY

1. Read all safety and operating instructions before using this product.
2. All safety and operating instructions should be retained for future reference.
3. Obey all cautions in the operating instructions and on the unit.
4. All operating instructions should be followed.
5. Use only shielded audio and data cables.
6. This product should not be used in the presence of moisture or rain, or near any water, i.e., a bathtub, sink, swimming pool, wet basement, etc.
7. This product should be located so that its position does not interfere with proper ventilation. Do not use in direct sunlight. Do not place flat against a wall or in a built-in enclosure that will impede the flow of cooling air.
8. This product should not be placed near a source of heat such as a stove or radiator.
9. Connect only to a power supply of the type marked on the unit adjacent to the power entry module.
10. Never break off the ground pin on the power supply cord.
11. Power supply cords should always be handled carefully. Never walk or place equipment on power supply cords. Periodically check cords for cuts or signs of stress, especially at the plug and the point where the cord exits the unit.
12. The power supply cord should be unplugged when the unit is to be unused for long periods of time.
13. Care should be taken so that objects do not fall and liquids are not spilled into the unit through the ventilation holes or any other openings.
14. This unit should be checked by a qualified service technician if:
 - A. The power supply cord or plug has been damaged.
 - B. Anything has fallen or been spilled into the unit.
 - C. The unit does not operate correctly.
 - D. The unit has been dropped or the enclosure damaged.
15. The user should not attempt to service this equipment. All service work should be done by a qualified service technician.

Section Twelve : Cautions and Warranties

CAUTION

EXPOSURE TO EXTREMELY HIGH NOISE LEVELS MAY CAUSE A PERMANENT HEARING LOSS. INDIVIDUALS VARY CONSIDERABLY IN SUSCEPTIBILITY TO NOISE INDUCED HEARING LOSS, BUT NEARLY EVERYONE WILL LOSE SOME HEARING IF EXPOSED TO SUFFICIENTLY INTENSE NOISE FOR A SUFFICIENT TIME. THE U.S. GOVERNMENT'S OCCUPATIONAL SAFETY AND HEALTH ADMINISTRATION (OSHA) HAS SPECIFIED THE FOLLOWING PERMISSIBLE NOISE LEVEL EXPOSURES:

DURATION/DAY IN HOURS	SOUND LEVEL IN dBA, SLOW RESPONSE
8	90
6	92
4	95
3	97
2	100
1-1/2	102
1	105
1/2	110
1/4 or less	115

ACCORDING TO OSHA, ANY EXPOSURE IN EXCESS OF THE ABOVE PERMISSIBLE LIMITS COULD RESULT IN HEARING LOSS. EAR PLUGS OR PROTECTORS IN THE EAR CANALS OR OVER THE EARS MUST BE WORN WHEN OPERATING THIS DEVICE IN ORDER TO PREVENT A PERMANENT HEARING LOSS, IF EXPOSURE IS IN EXCESS OF THE LIMITS AS SET FORTH ABOVE. TO ENSURE AGAINST POTENTIALLY DANGEROUS EXPOSURE TO HIGH SOUND PRESSURE LEVELS, IT IS RECOMMENDED THAT ALL PERSONS EXPOSED TO EQUIPMENT CAPABLE OF PRODUCING HIGH SOUND PRESSURE LEVELS SUCH AS THIS DEVICE BE PROTECTED BY HEARING PROTECTORS WHILE THIS UNIT IS IN OPERATION.

FBX and FBX Feedback Exterminator are registered trademarks of Sabine, Inc., and are the brand names of its line of automatic feedback controllers. Covered by U.S. Patent No. 5,245,665, Australian Patent No. 653,736, Canadian Patent No. 2,066,624-2, German Patent No. 69118486.0, and U.K. Patent No. 0486679. Other patents pending.

True Mobility, Graphi-Q, Power-Q, Real-Q, and Real-Q2 are trademarks of Sabine, Inc.

Copyright 2002. All rights reserved.

Limited Warranty

THIS LIMITED WARRANTY VALID ONLY WHEN PURCHASED AND REGISTERED IN THE UNITED STATES OR CANADA. ALL EXPORTED PRODUCTS ARE SUBJECT TO WARRANTY AND SERVICES TO BE SPECIFIED AND PROVIDED BY THE AUTHORIZED DISTRIBUTOR FOR EACH COUNTRY.

Ces clauses de garantie ne sont valables qu'aux Etats-Unis et au Canada. Dans tous les autres pays, les clauses de garantie et de maintenance sont fixées par le distributeur national et assurées par lui selon la législation en vigueur.

Diese Garantie ist nur in den USA und Kanada gültig. Alle Export-Produkte sind der Garantie und dem Service des Importeurs des jeweiligen Landes unterworfen.

Esta garantía es válida solamente cuando el producto es comprado en E.U. continentales o en Canada. Todos los productos que sean comprados en el extranjero, están sujetos a las garantías y servicio que cada distribuidor autorizado determine y otorgue en los diferentes países.

ONE-YEAR LIMITED WARRANTY/REMEDY

SABINE, INC. ("SABINE") warrants this product to be free from defects in material and workmanship for a period of one (1) year from date of purchase PROVIDED, however, that this limited warranty is extended only to the original retail purchaser and is subject to the conditions, exclusions and limitations hereinafter set forth:

CONDITIONS, EXCLUSIONS AND LIMITATIONS OF LIMITED WARRANTIES

These limited warranties shall be void and of no effect if:

- The first purchase of the product is for the purpose of resale; or
- The original retail purchase is not made from an AUTHORIZED SABINE DEALER; or
- The product has been damaged by accident or unreasonable use, neglect, improper service or maintenance, or other causes not arising out of defects in material or workmanship; or
- The serial number affixed to the product is altered, defaced or removed; or
- The power supply grounding pin is removed or otherwise defeated. In the event of a defect in material and/or workmanship covered by this limited warranty, Sabine will repair the defect in material or workmanship or replace the product, at Sabine's option; and provided, however, that, in any case, all costs of shipping, if necessary, are paid by you, the purchaser.

THE WARRANTY REGISTRATION CARD SHOULD BE ACCURATELY COMPLETED, MAILED TO AND RECEIVED BY SABINE WITHIN FOURTEEN (14) DAYS FROM THE DATE OF YOUR PURCHASE.

In order to obtain service under these warranties, you must:

- Bring the defective item to any Authorized SABINE DEALER and present therewith the ORIGINAL PROOF OF PURCHASE supplied to you by the AUTHORIZED SABINE DEALER in connection with your purchase from him of this product. If the DEALER is unable to provide the necessary warranty service, you will be directed to the nearest other SABINE AUTHORIZED DEALER which can provide such service.

OR

- Ship the defective item, prepaid, to:

SABINE, INC.
13301 HIGHWAY 441
ALACHUA, FL 32615-8544

including therewith a complete, detailed description of the problem, together with a legible copy of the original PROOF OF PURCHASE and a complete return address. Upon Sabine's receipt of these items:

If the defect is remedial under the limited warranties and the other terms and conditions expressed have been complied with, Sabine will provide the necessary warranty service to repair or replace the product and will return it, FREIGHT COLLECT, to you, the purchaser. Sabine's liability to the purchaser for damages from any cause whatsoever and regardless of the form of action, including negligence, is limited to the actual damages up to the greater of \$500.00 or an amount equal to the purchase price of the product that caused the damage or that is the subject of or is directly related to the cause of action. Such purchase price will be that in effect for the specific product when the cause of action arose. This limitation of liability

will not apply to claims for personal injury or damage to real property or tangible personal property allegedly caused by Sabine's negligence. Sabine does not assume liability for personal injury or property damage arising out of or caused by a non-Sabine alteration or attachment, nor does Sabine assume any responsibility for damage to interconnected non-Sabine equipment that may result from the normal functioning and maintenance of the Sabine equipment.

UNDER NO CIRCUMSTANCES WILL SABINE BE LIABLE FOR ANY LOST PROFITS, LOST SAVINGS, ANY INCIDENTAL DAMAGES OR ANY CONSEQUENTIAL DAMAGES ARISING OUT OF THE USE OR INABILITY TO USE THE PRODUCT, EVEN IF SABINE HAS BEEN ADVISED OF THE POSSIBILITY OF SUCH DAMAGES.

THESE LIMITED WARRANTIES ARE IN LIEU OF ANY AND ALL WARRANTIES, EXPRESS OR IMPLIED, INCLUDING BUT NOT LIMITED TO, THE IMPLIED WARRANTIES OF MERCHANTABILITY AND FITNESS FOR A PARTICULAR USE; PROVIDED, HOWEVER, THAT IF THE OTHER TERMS AND CONDITIONS NECESSARY TO THE EXISTENCE OF THE EXPRESS LIMITED WARRANTIES, AS HEREINABOVE STATED, HAVE BEEN COMPLIED WITH, IMPLIED WARRANTIES ARE NOT DISCLAIMED DURING THE APPLICABLE ONE-YEAR PERIOD FROM DATE OF PURCHASE OF THIS PRODUCT.

SOME STATES DO NOT ALLOW LIMITATION ON HOW LONG AN IMPLIED WARRANTY LASTS, OR THE EXCLUSION OR LIMITATION OF INCIDENTAL OR CONSEQUENTIAL DAMAGES, SO THE ABOVE LIMITATIONS OR EXCLUSIONS MAY NOT APPLY TO YOU. THESE LIMITED WARRANTIES GIVE YOU SPECIFIC LEGAL RIGHTS, AND YOU MAY ALSO HAVE OTHER RIGHTS WHICH MAY VARY FROM STATE TO STATE.

THESE LIMITED WARRANTIES ARE THE ONLY EXPRESS WARRANTIES ON THIS PRODUCT, AND NO OTHER STATEMENT, REPRESENTATION, WARRANTY OR AGREEMENT BY ANY PERSON SHALL BE VALID OR BINDING UPON SABINE.

In the event of any modification or disclaimer of express or implied warranties, or any limitation of remedies, contained herein conflicts with applicable law, then such modification, disclaimer or limitation, as the case may be, shall be deemed to be modified to the extent necessary to comply with such law.

Your remedies for breach of these warranties are limited to those remedies provided herein, and Sabine gives this limited warranty only with respect to equipment purchased in the United States of America.

INSTRUCTIONS-WARRANTY REGISTRATION CARD

1. Mail the completed WARRANTY REGISTRATION CARD to:

SABINE, INC.
13301 HIGHWAY 441
ALACHUA, FL 32615-8544

- a. Keep the PROOF OF PURCHASE. In the event warranty service is required during the warranty period, you will need this document. There will be no identification card issued by Sabine, Inc.

2. IMPORTANCE OF WARRANTY REGISTRATION CARDS AND NOTIFICATION OF CHANGES OF ADDRESS:

- a. Completion and mailing of WARRANTY REGISTRATION CARDS - Should notification become necessary for any condition that may require correction, the REGISTRATION CARD will help ensure that you are contacted and properly notified.

- b. Notice of address changes - If you move from the address shown on the WARRANTY REGISTRATION CARD, you should notify Sabine of the change of address so as to facilitate your receipt of any bulletins or other forms of notification which may become necessary in connection with any condition that may require dissemination of information or correction.

3. You may contact Sabine directly by telephoning (386) 418-2000.

4. Please have the Sabine product name and serial number available when communicating with Sabine Customer Service.

MADE IN TAIWAN and USA

Manufactured by: Sabine, Inc.

13301 Highway 441

Alachua, Florida 32615-8544 USA

Phone: (386) 418-2000 • Fax: (386) 418-2001

www.Sabine.com

SABINE[®]
ADAPTIVE AUDIO

© 2003 Sabine, Inc.

B2-SWM-Op-Guide-v4.pmd 030108-hto

Index

Symbols

1/10-octave Filter 32
 1/3 octave Filter 19
 1/3-octave Filter 20
 1/4-inch Jack 10, 12
 1/5-octave Filter 32, 33

A

Accessory 9
 Amplifier 10, 22
 Antenna 6, 7, 8, 9, 12, 28, 30
 Antenna Accessories 9
 Antenna Booster 7, 9
 Antenna Boosters 28
 Antenna Connections 11
 Antenna Converter Kit 7, 12
 Antenna Divider 7, 11, 37
 Antenna Extension 11
 Audio Output 16
 Audio Output Connection 12
 Audio signal meter 7

B

Balanced Out 8, 10
 Battery Charger 7, 8, 16, 18, 28
 Beltpack Transmitter 9, 10, 13, 16, 17
 Beltpack Transmitter Schematic 35
 Bypass 10, 23

C

Carrier Frequency Range 36
 Clipping 14
 Compressor 7
 Compressor (Over Compression) 27
 Compressor Attack 25, 26, 27, 37
 Compressor Breathing 27
 Compressor Knee 25, 37
 Compressor Ratio 25
 Compressor Release 27
 Compressor Threshold 13, 25, 27, 37
 Current Drain 37

D

De-Esser 6, 7, 8, 24, 37
 De-Esser Cut Range 37
 De-Esser Set Up 24
 Declaration of Conformity 3
 Dynamic FBX filter 21
 Dynamic Microphone 35
 Dynamic Range 36

E

Electret Condenser Microphone 35
 Electric Guitar 35
 European RTTE Directive 37
 Extension Antenna 6, 7, 28

F

FBX Configuration DIP Switch 22, 33
 FBX Dynamic Filter 23
 FBX Feedback Exterminator 7
 FBX Filter 6, 10
 FBX Filter Width 22, 33, 37
 FBX Fixed Filter 21, 23
 Feedback 19
 Filters (Constant Q) 21
 Filters (Proportional Q) 21
 FM Deviation 36
 Frequency (Quick Setup) 10
 Frequency (Unused Group) 14
 Frequency Group 10, 28, 30, 31, 32
 Frequency Group & Channel Selection 14

G

Graphic EQ 19, 20, 22
 Guitar Compression 26
 Guitar Output 12

H

Handheld Microphone 9, 10, 14, 17, 22

I

Image Rejection 36
 Indicator LED 8
 Interference 29
 Intermodulation Distortion 29, 30, 31

L

Level Switch 10, 12, 37

M

Maximum Deviation 36
 Mic Bias 36
 Mic Connector 36
 Mic Input Impedance 36
 Microphone 10, 23
 Microphone (Lavalier) 13, 19
 Microphone Element 36
 Microphone Location 10, 11
 Microphone Transmitter 6
 Multiple System Installation 28

N

NiCAD rechargeable battery 7
 NiMH 9-Volt Battery 7, 16, 18, 28
 Noise 27
 Noise (Compressor) 27
 Noise (from electrical sources) 12
 Noise (overall system noise) 22
 Noise (Troubleshooting) 28
 Noise Figure 37
 Noise Floor 25, 27
 Noise Gate 22
 Noise Rejection 6
 Noise Squelch 7
 Nominal Audio Output Level 36

O

Oscillation Mode 36
 Output Impedance 36
 Output (Amplifier) 22
 Output (Balanced) 12, 16
 Output (Mixer) 20
 Output (Unbalanced) 8, 10, 12, 16, 37
 Output Configuration 36
 Output Gain 27
 Output Level 8, 10, 22, 23, 28
 Output Port Isolation 37

P

Phase Locked Loop 6
 Power Supply 37

Q

Quick Setup 6, 10

R

Release 37
 RF Frequency Stability 36
 RF Meter 7
 RF Output 36
 RF Signal 7, 8, 10, 13, 28

S

S/N Ratio 16, 27, 36, 37
 Sensitivity 36
 Setup Button 23
 Setup Process 23
 Software Installation 38
 Spurious Rejection 36
 Squelch 7, 8, 13, 17, 28
 Squelch Control 13
 Squelch Quieting 36

T

Targeted Input Processing 6
 THD 36
 Thresh (Compressor Threshold) 25
 Transducer type 36
 Transmitter Frequency 29, 30
 Transmitter Frequency (Export) 30
 Transmitter Gain 10
 Transmitter Operating Procedures 13
 Transmitter Operation 28
 Transmitter Setup 10, 11, 23
 Transmitter/Receiver Path 28
 Transmitters (Multiple) 15
 True Diversity 7

V

Vocal Compression 26

W

Warranty 38
 Wiring Diagram 34

X

XLR connector 12